

REVISIONS				
ZONE	REV	DESCRIPTION	DATE	APPROVED

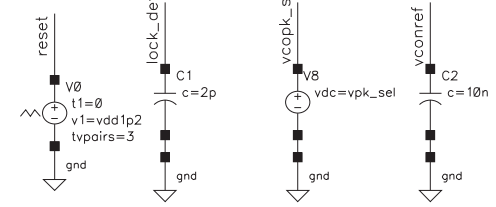
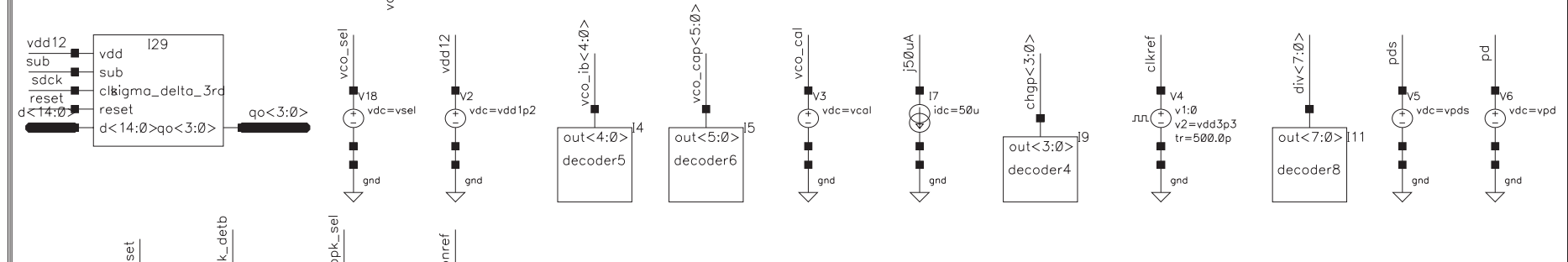
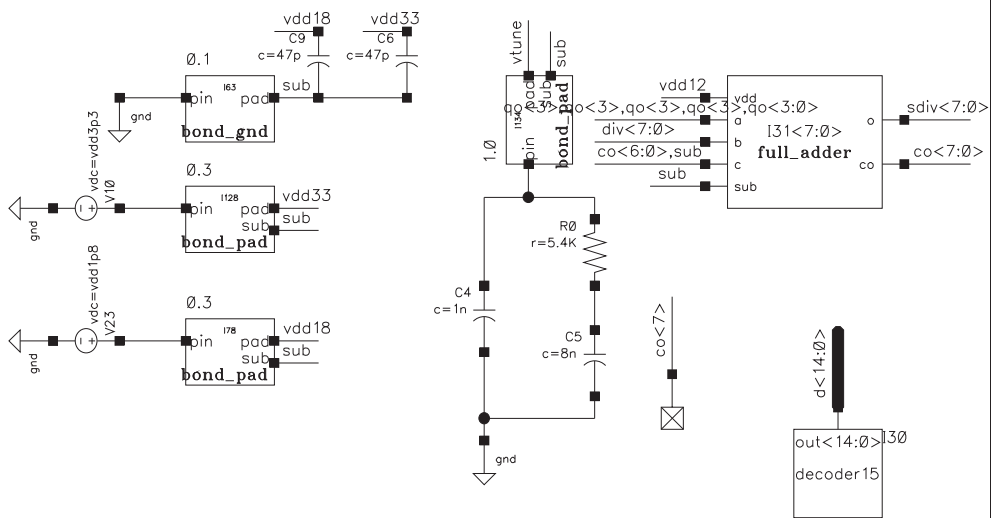
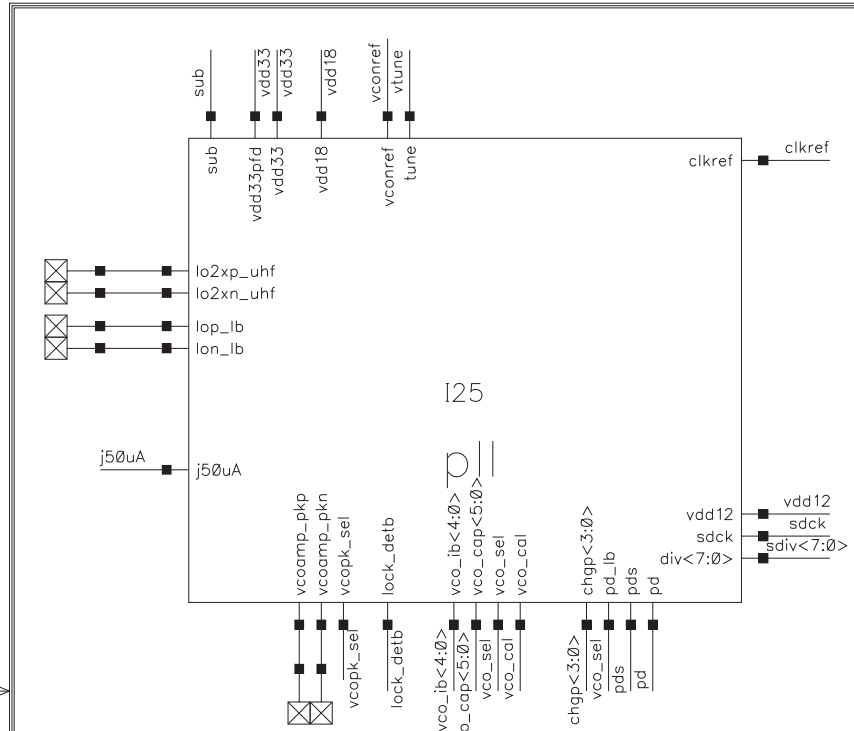

UPDATED	Dec 14 03:02:22 2006			O2 Micro Inc. PLL Testbench	
DRAWN					
CHECKED				SIZE	CAGE NO.
CHECKED				DWG NO.	REV
ISSUED				SCALE	SHEET 1 OF 1

REVISIONS				
ZONE	REV	DESCRIPTION	DATE	APPROVED

Currents:
VDD18: 25mA; VDD33: 1.5mA; VDD12: 200uA with digital spikes.
In PDS: VDD18: 0.4mA, VDD33: 0

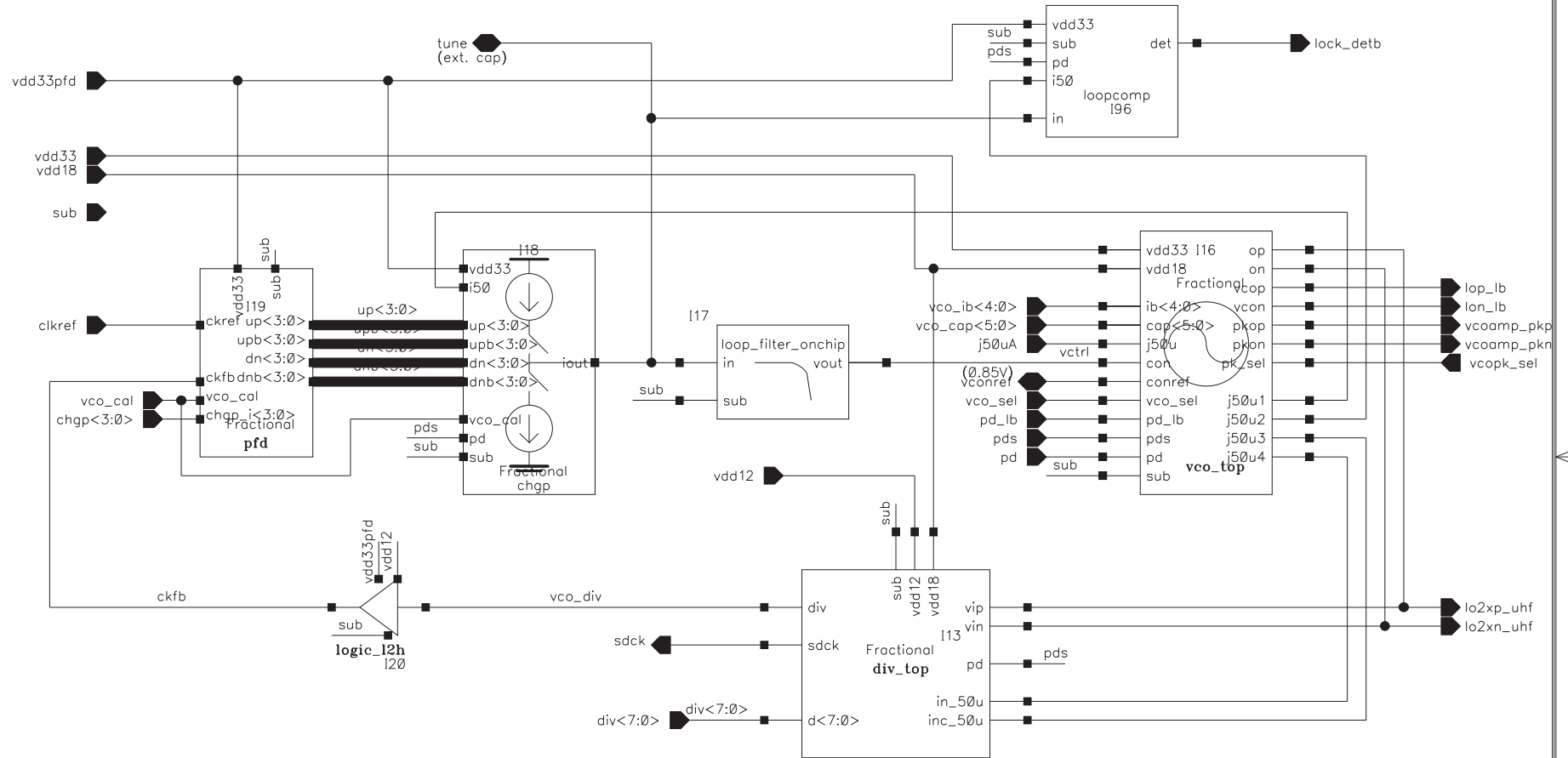

UPDATED	Oct 25 01:50:09 2006			
DRAWN	pll_top			
CHECKED	SIZE	CAGE NO.	DWG NO.	REV
CHECKED	A			
ISSUED	SCALE	SHEET 1 OF 1		

REVISIONS				
ZONE	REV	DESCRIPTION	DATE	APPROVED

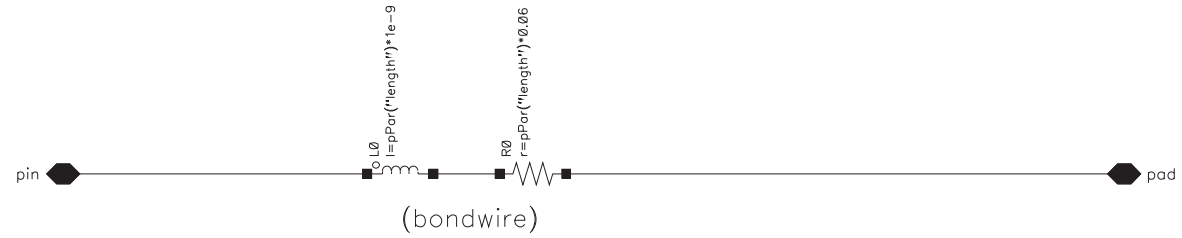

UPDATED	Oct 25 01:50:10 2006			
DRAWN	Bond_gnd			
CHECKED				
CHECKED	SIZE	CAGE NO.	DWG NO.	REV
ISSUED	A			1.0
	SCALE		SHEET	1 OF 1

REVISIONS				
ZONE	REV	DESCRIPTION	DATE	APPROVED

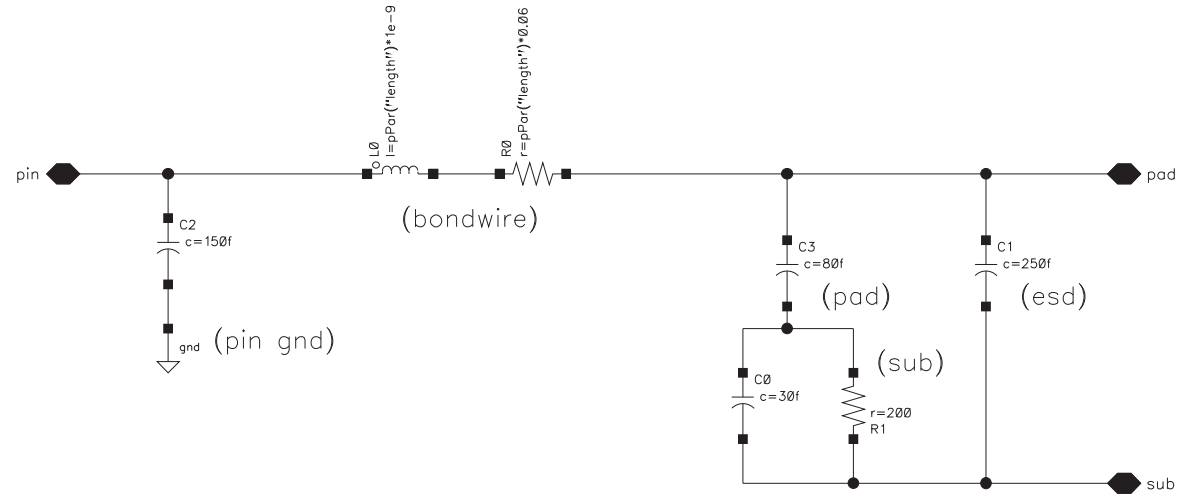

UPDATED	Oct 25 01:50:10 2006			
DRAWN	Bond_pad			
CHECKED				
CHECKED	SIZE	CAGE NO.	DWG NO.	REV
ISSUED	A			1.0
SCALE		SHEET		1 OF 1

REVISIONS				
ZONE	REV	DESCRIPTION	DATE	APPROVED

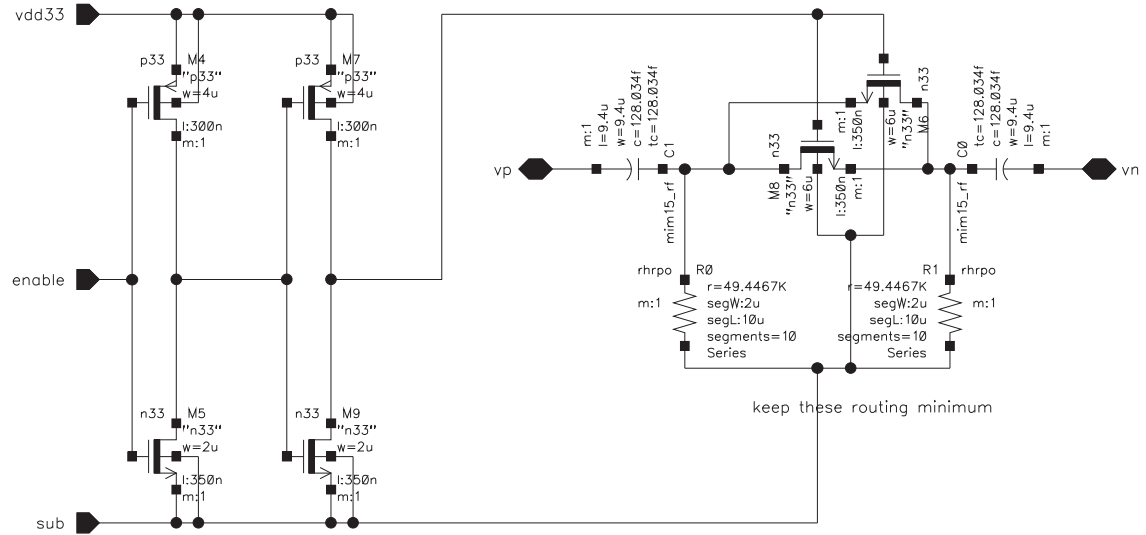

UPDATED	Oct 25 01:50:08 2006			
DRAWN	cap_vco1switch_b0			
CHECKED				
CHECKED	SIZE	CAGE NO.	DWG NO.	REV
ISSUED	A			
	SCALE			SHEET 1 OF 1

REVISIONS				
ZONE	REV	DESCRIPTION	DATE	APPROVED

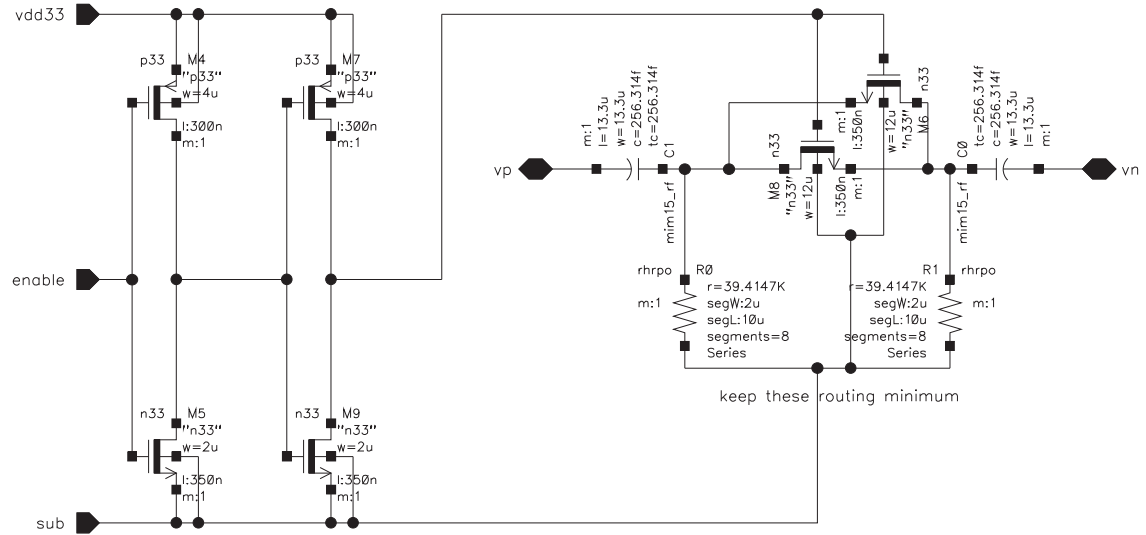

UPDATED	Oct 25 01:50:08 2006			
DRAWN	cap_vco1switch_b1			
CHECKED				
CHECKED	SIZE	CAGE NO.	DWG NO.	REV
ISSUED	A			
	SCALE		SHEET	1 OF 1

REVISIONS				
ZONE	REV	DESCRIPTION	DATE	APPROVED

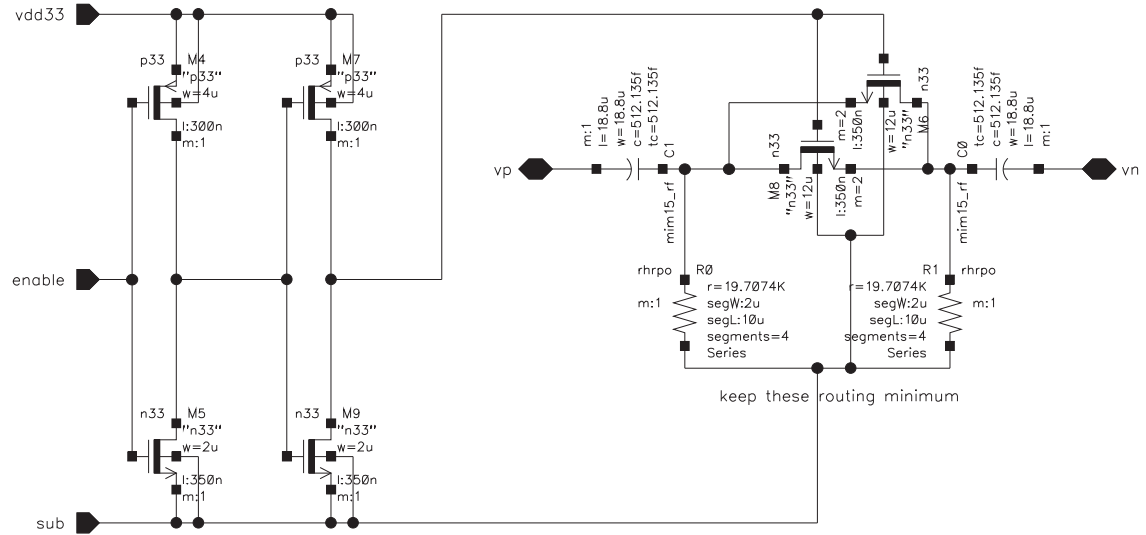

UPDATED	Oct 25 01:50:08 2006			
DRAWN	cap_vco1switch_b2			
CHECKED				
CHECKED	SIZE	CAGE NO.	DWG NO.	REV
ISSUED	A			
	SCALE		SHEET	1 OF 1

REVISIONS				
ZONE	REV	DESCRIPTION	DATE	APPROVED

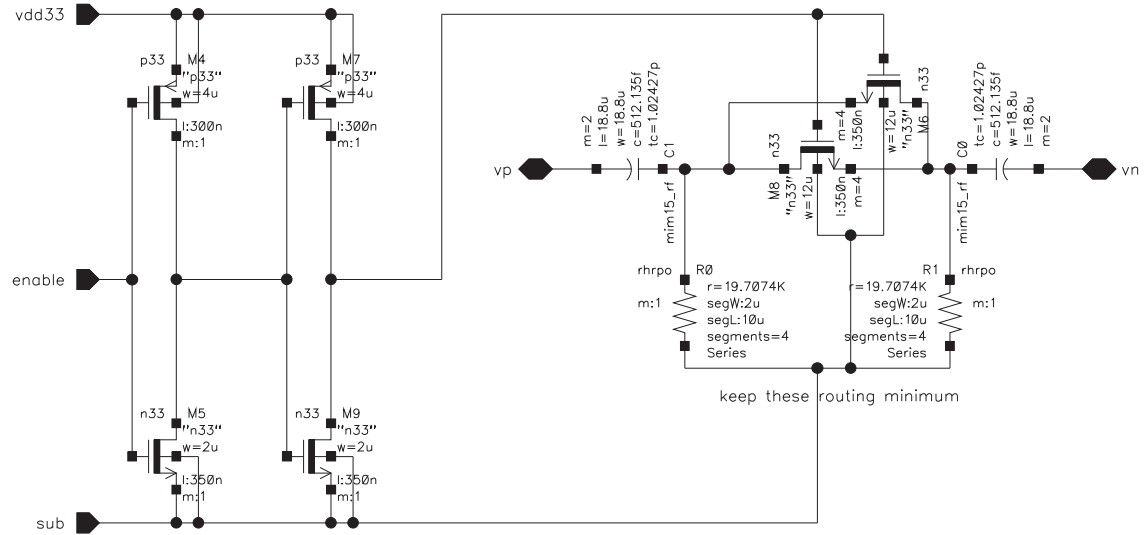

UPDATED	Oct 25 01:50:08 2006			
DRAWN	cap_vco1switch_b3			
CHECKED				
CHECKED	SIZE	CAGE NO.	DWG NO.	REV
ISSUED	A			
	SCALE		SHEET	1 OF 1

REVISIONS				
ZONE	REV	DESCRIPTION	DATE	APPROVED

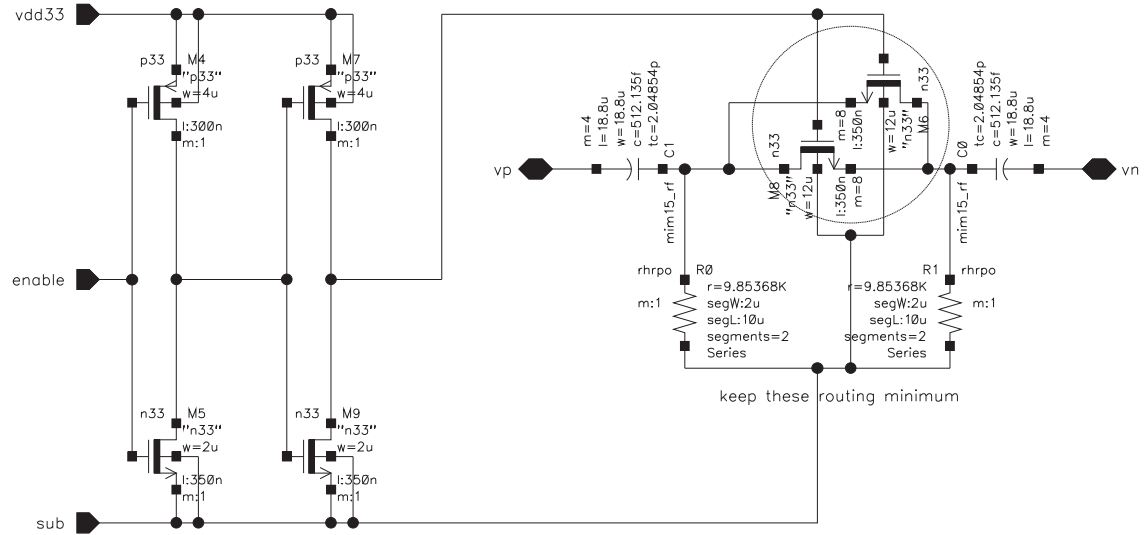

UPDATED	Oct 25 01:50:08 2006			
DRAWN	cap_vco1switch_b4			
CHECKED				
CHECKED	SIZE	CAGE NO.	DWG NO.	REV
ISSUED	A			
	SCALE		SHEET	1 OF 1

REVISIONS				
ZONE	REV	DESCRIPTION	DATE	APPROVED

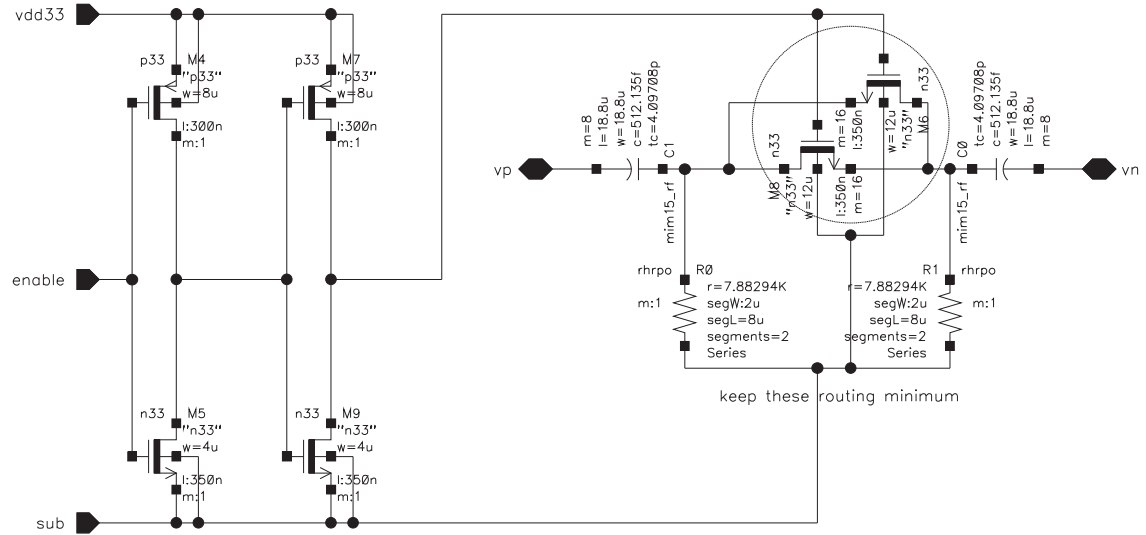

UPDATED	Oct 25 01:50:08 2006			
DRAWN	cap_vco1switch_b5			
CHECKED				
CHECKED	SIZE	CAGE NO.	DWG NO.	REV
ISSUED	A			
	SCALE		SHEET	1 OF 1

REVISIONS				
ZONE	REV	DESCRIPTION	DATE	APPROVED

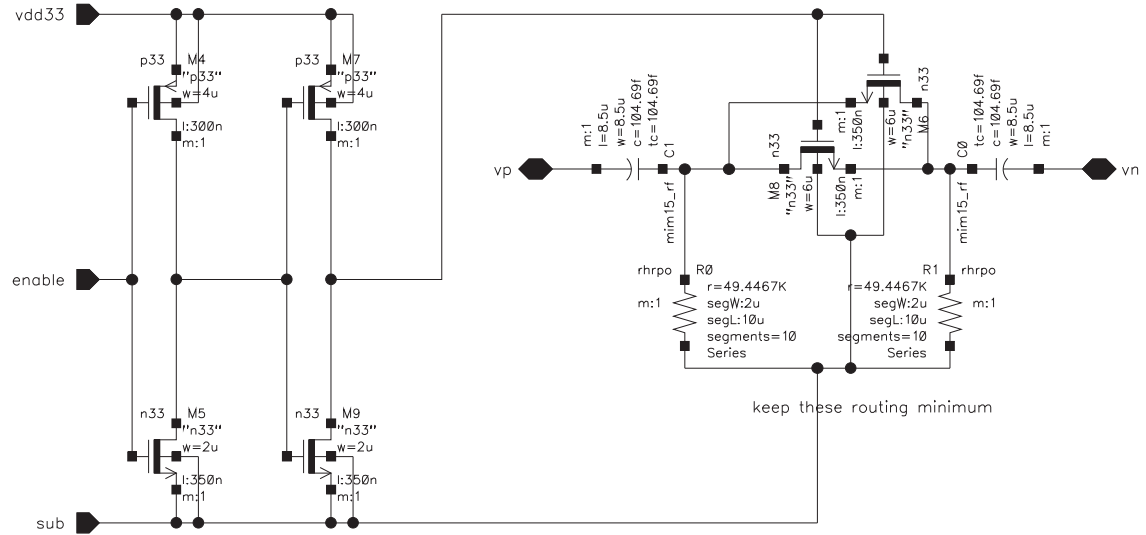

UPDATED	Oct 25 01:50:08 2006
DRAWN	
CHECKED	
CHECKED	
ISSUED	

cap_vco2switch_b0			
SIZE	CAGE NO.	DWG NO.	REV
A			
SCALE	SHEET		1 OF 1

REVISIONS				
ZONE	REV	DESCRIPTION	DATE	APPROVED

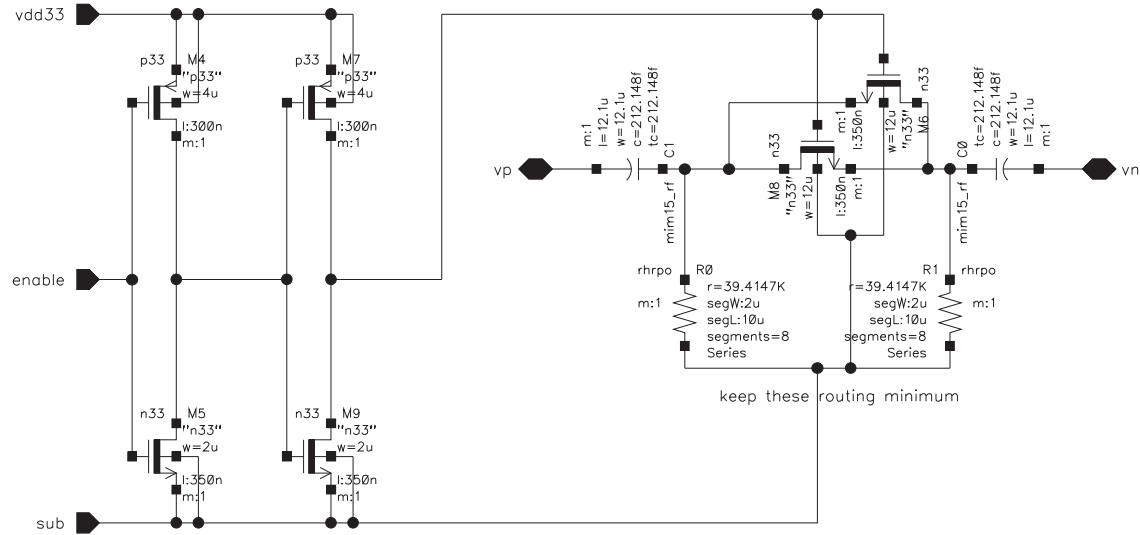

UPDATED	Oct 25 01:50:08 2006			
DRAWN	cap_vco2switch_b1			
CHECKED				
CHECKED	SIZE	CAGE NO.	DWG NO.	REV
ISSUED	A			
SCALE			SHEET	1 OF 1

REVISIONS				
ZONE	REV	DESCRIPTION	DATE	APPROVED

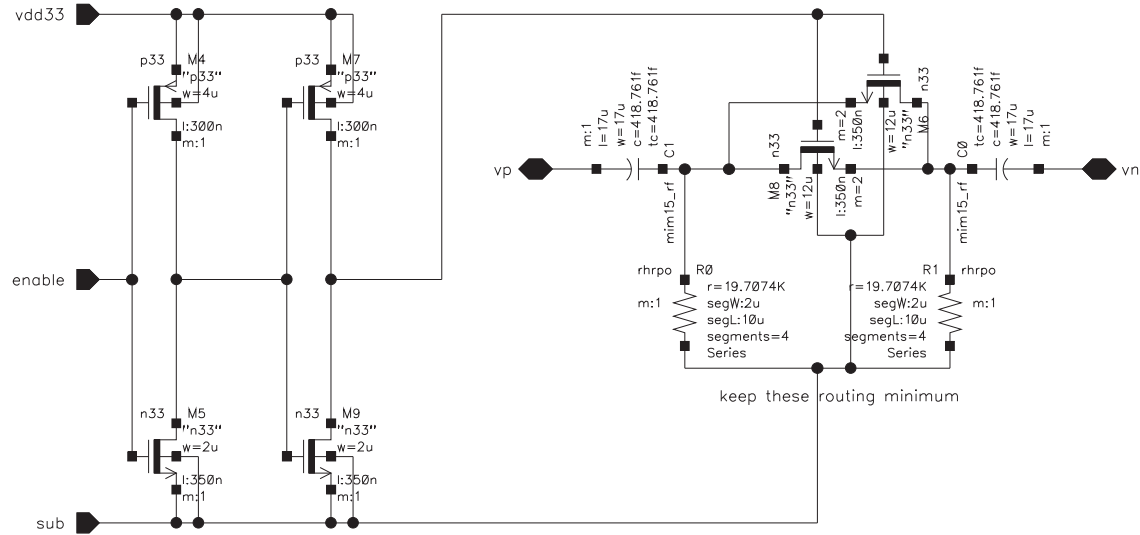

UPDATED	Oct 25 01:50:08 2006			
DRAWN	cap_vco2switch_b2			
CHECKED				
CHECKED	SIZE	CAGE NO.	DWG NO.	REV
ISSUED	A			
	SCALE		SHEET	1 OF 1

REVISIONS				
ZONE	REV	DESCRIPTION	DATE	APPROVED

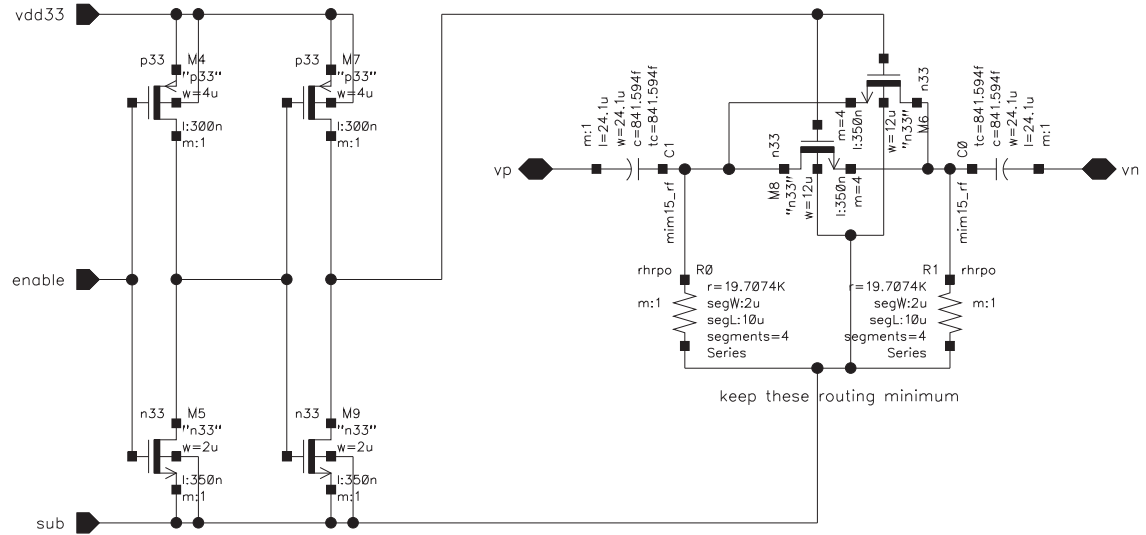

UPDATED	Oct 25 01:50:08 2006			
DRAWN	cap_vco2switch_b3			
CHECKED				
CHECKED	SIZE	CAGE NO.	DWG NO.	REV
ISSUED	A			
	SCALE	SHEET		1 OF 1

REVISIONS				
ZONE	REV	DESCRIPTION	DATE	APPROVED

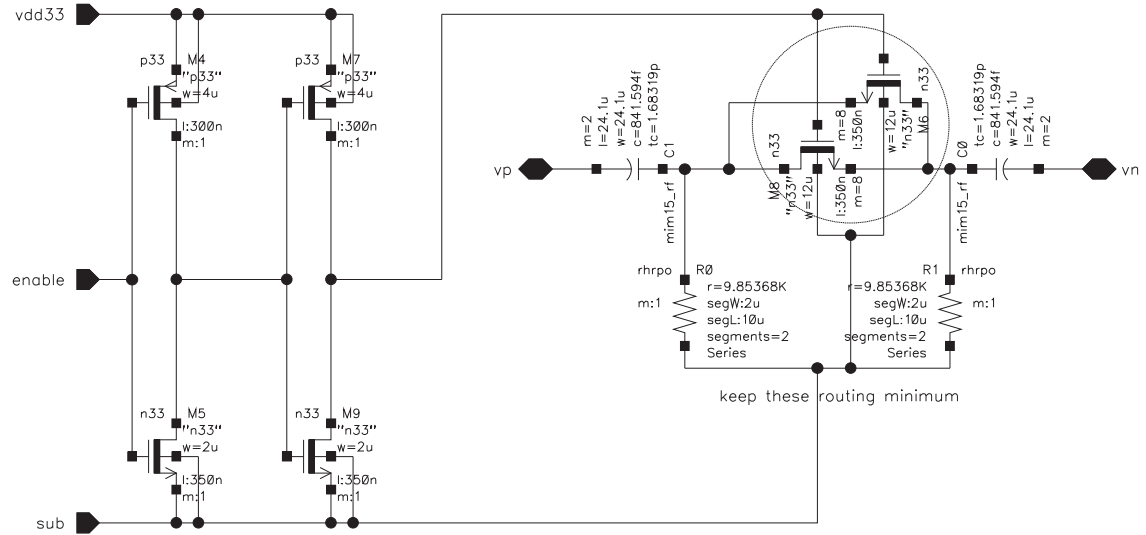

UPDATED	Oct 25 01:50:08 2006			
DRAWN	cap_vco2switch_b4			
CHECKED				
CHECKED	SIZE	CAGE NO.	DWG NO.	REV
ISSUED	A			
	SCALE			SHEET 1 OF 1

REVISIONS				
ZONE	REV	DESCRIPTION	DATE	APPROVED

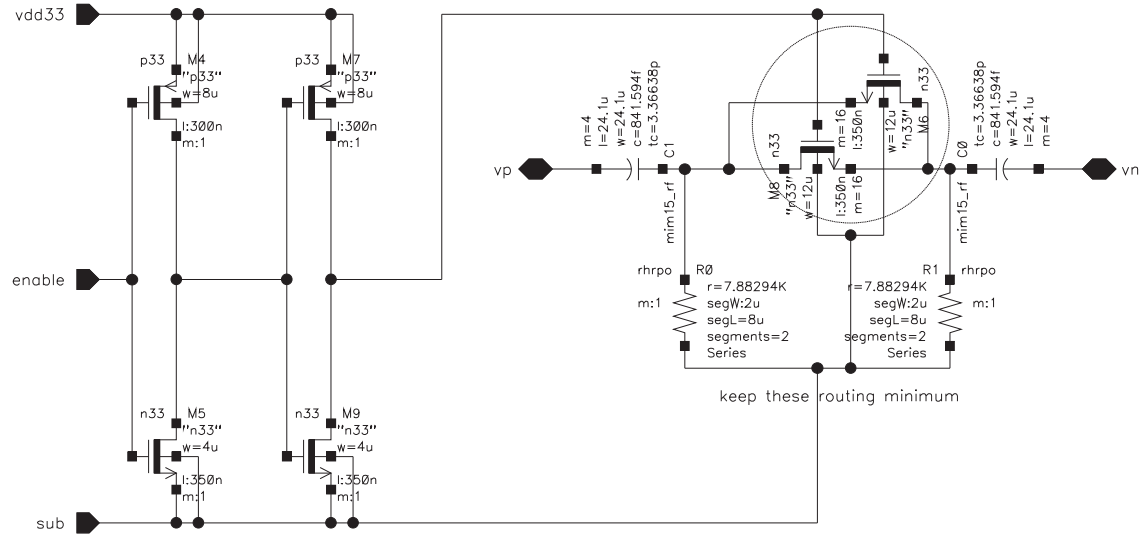

UPDATED	Oct 25 01:50:08 2006			
DRAWN	cap_vco2switch_b5			
CHECKED				
CHECKED	SIZE	CAGE NO.	DWG NO.	REV
ISSUED	A			
	SCALE		SHEET	1 OF 1

REVISIONS				
ZONE	REV	DESCRIPTION	DATE	APPROVED
			50u	

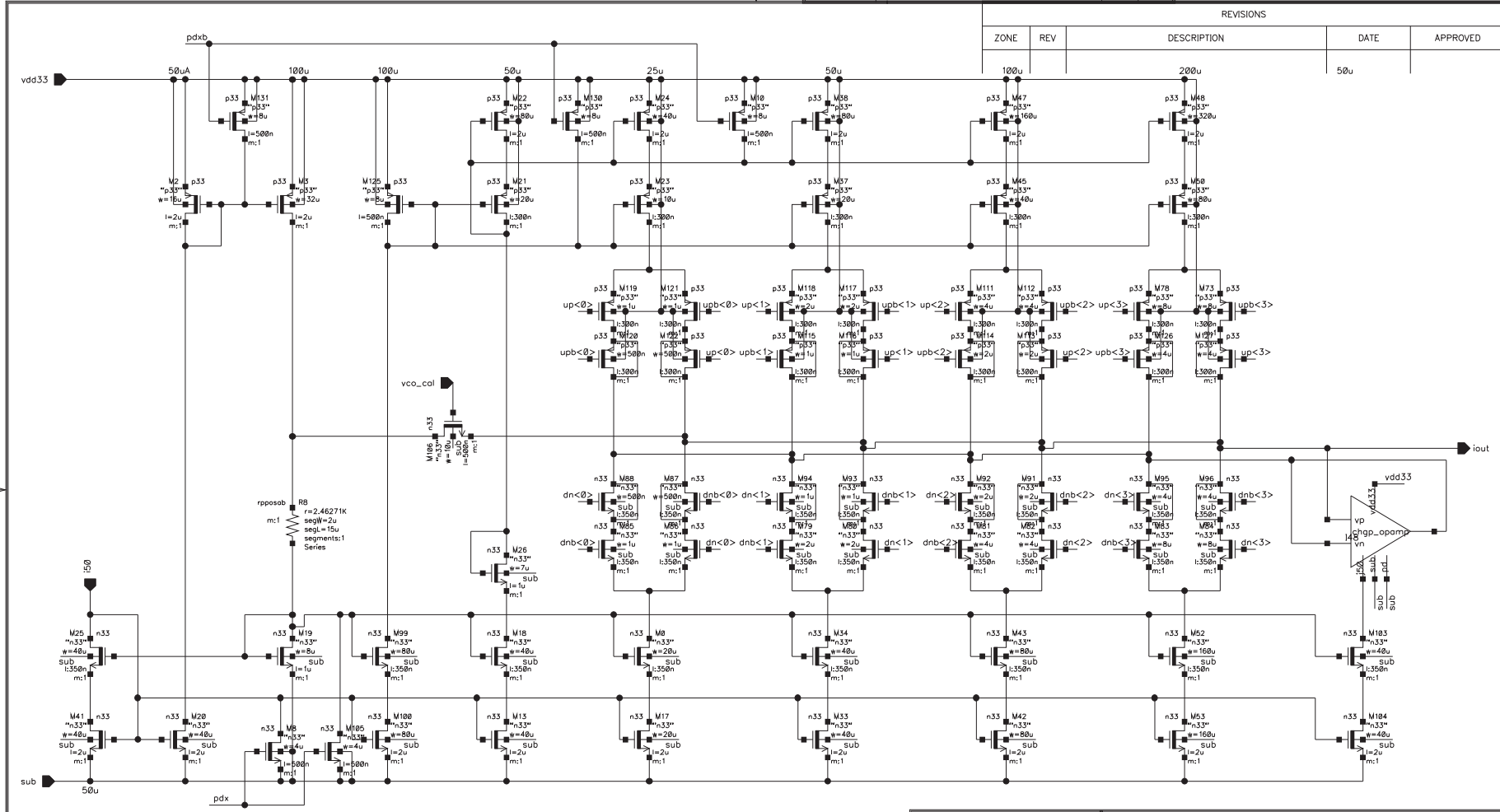

- up<3:0>
- upb<3:0>
- dn<3:0>
- dnb<3:0>

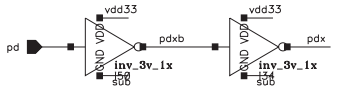

UPDATED	Oct 25 01:50:08 2006			
DRAWN	chgp			
CHECKED				
CHECKED	SIZE	CAGE NO.	DWG NO.	REV
ISSUED	B			
	SCALE		SHEET	1 OF 1

REVISIONS				
ZONE	REV	DESCRIPTION	DATE	APPROVED

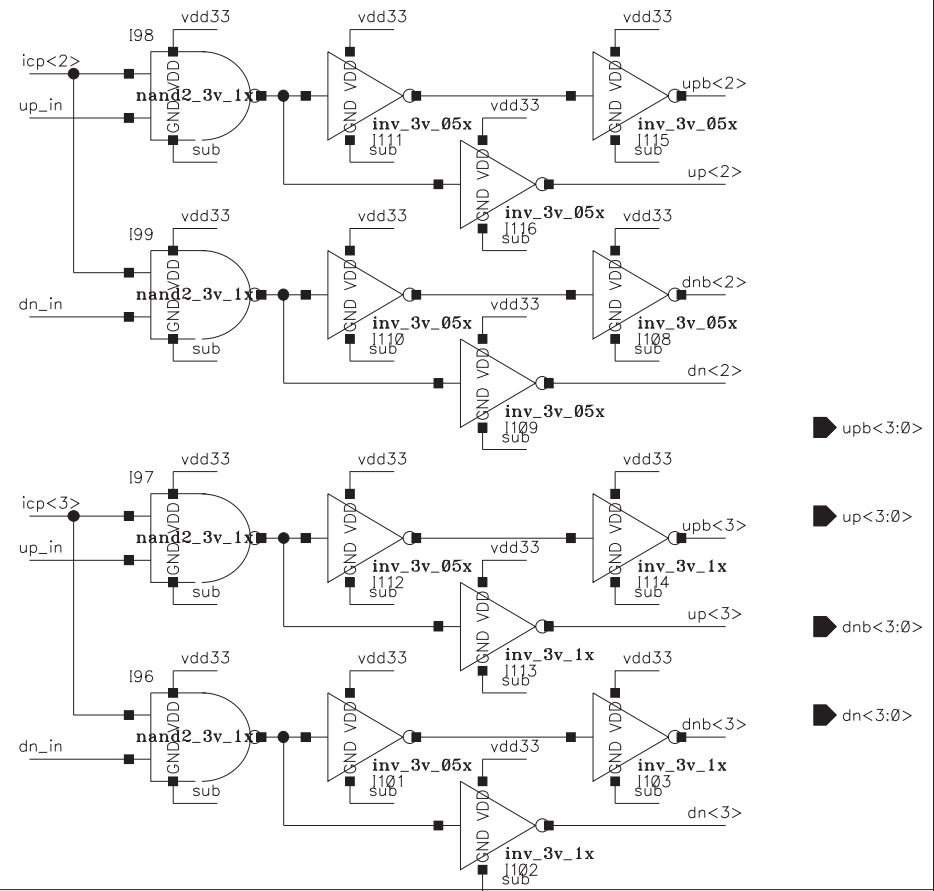
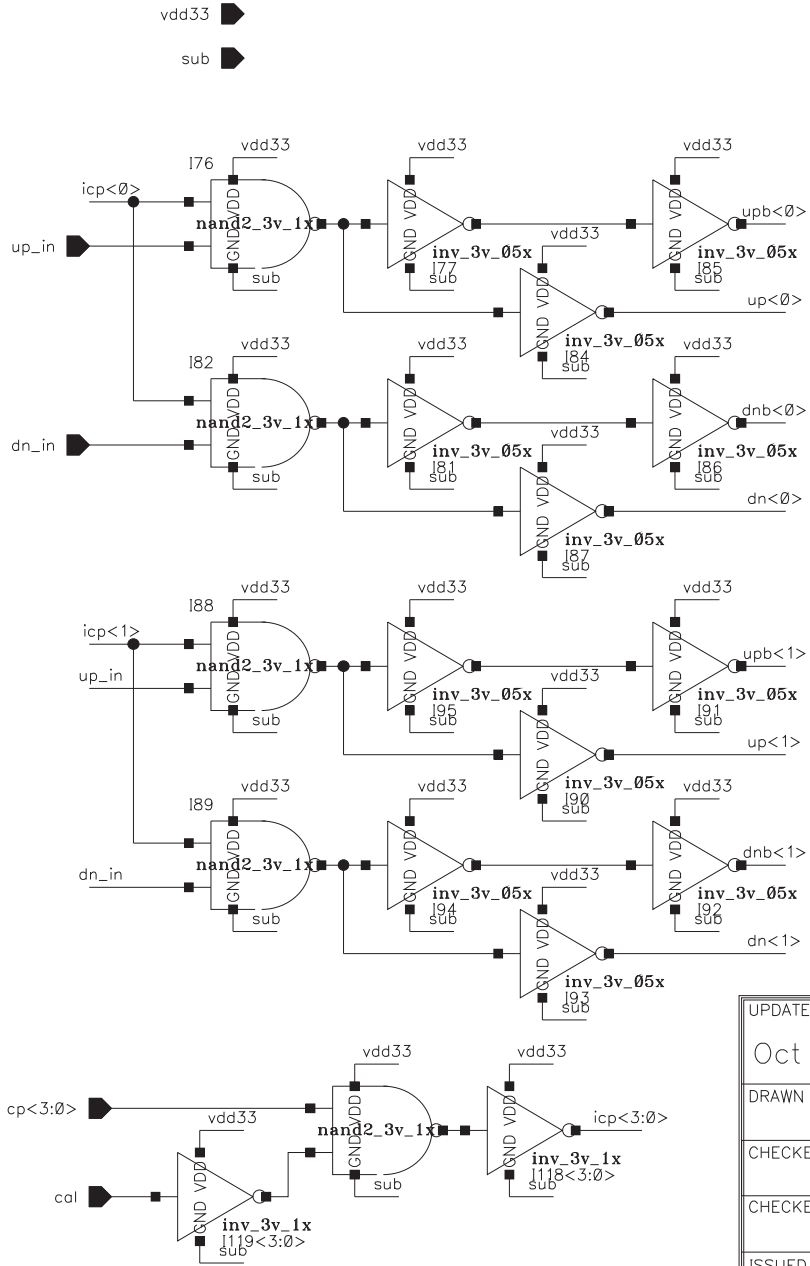

UPDATED	Oct 25 01:50:08 2006		
DRAWN	chgp_logic		
CHECKED			
CHECKED			
ISSUED			
	SIZE	CAGE NO.	DWG NO.
	A		
	SCALE		SHEET 1 OF 1

REVISIONS				
ZONE	REV	DESCRIPTION	DATE	APPROVED

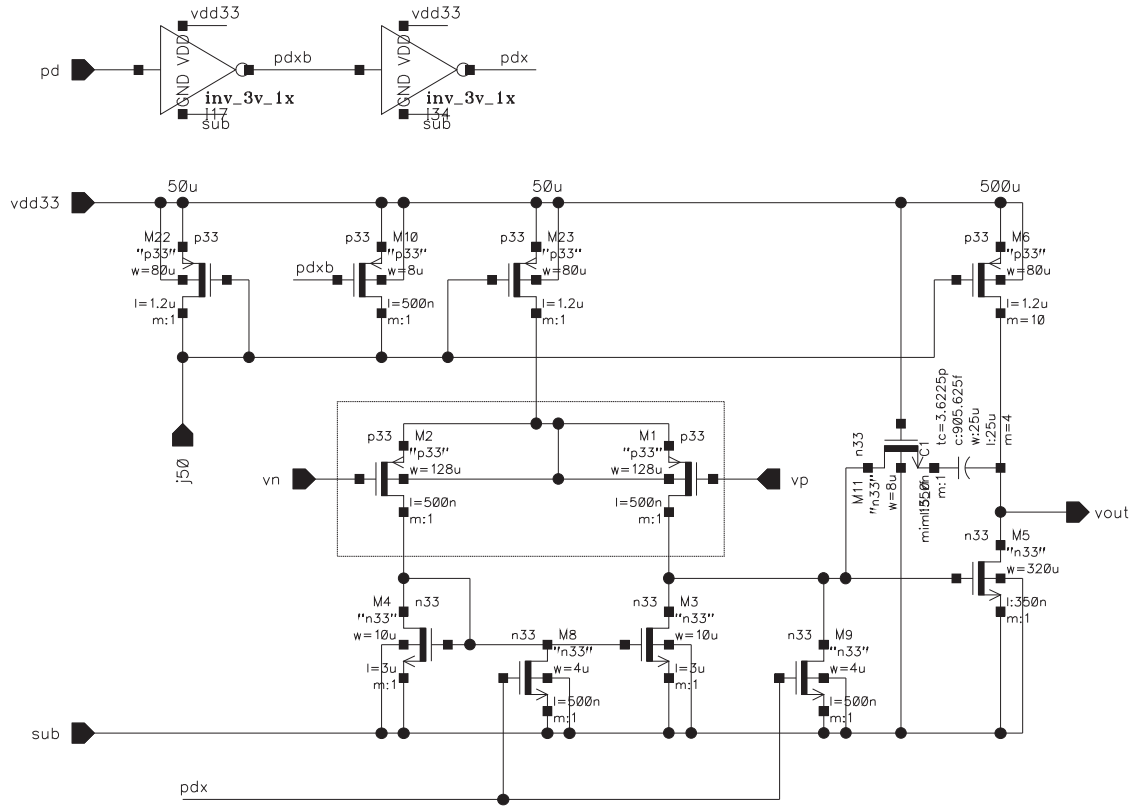

UPDATED	Oct 25 01:50:08 2006
DRAWN	
CHECKED	
CHECKED	
ISSUED	

chgp_opamp			
SIZE	CAGE NO.	DWG NO.	REV
A			
SCALE	SHEET		OF

REVISIONS				
ZONE	REV	DESCRIPTION	DATE	APPROVED

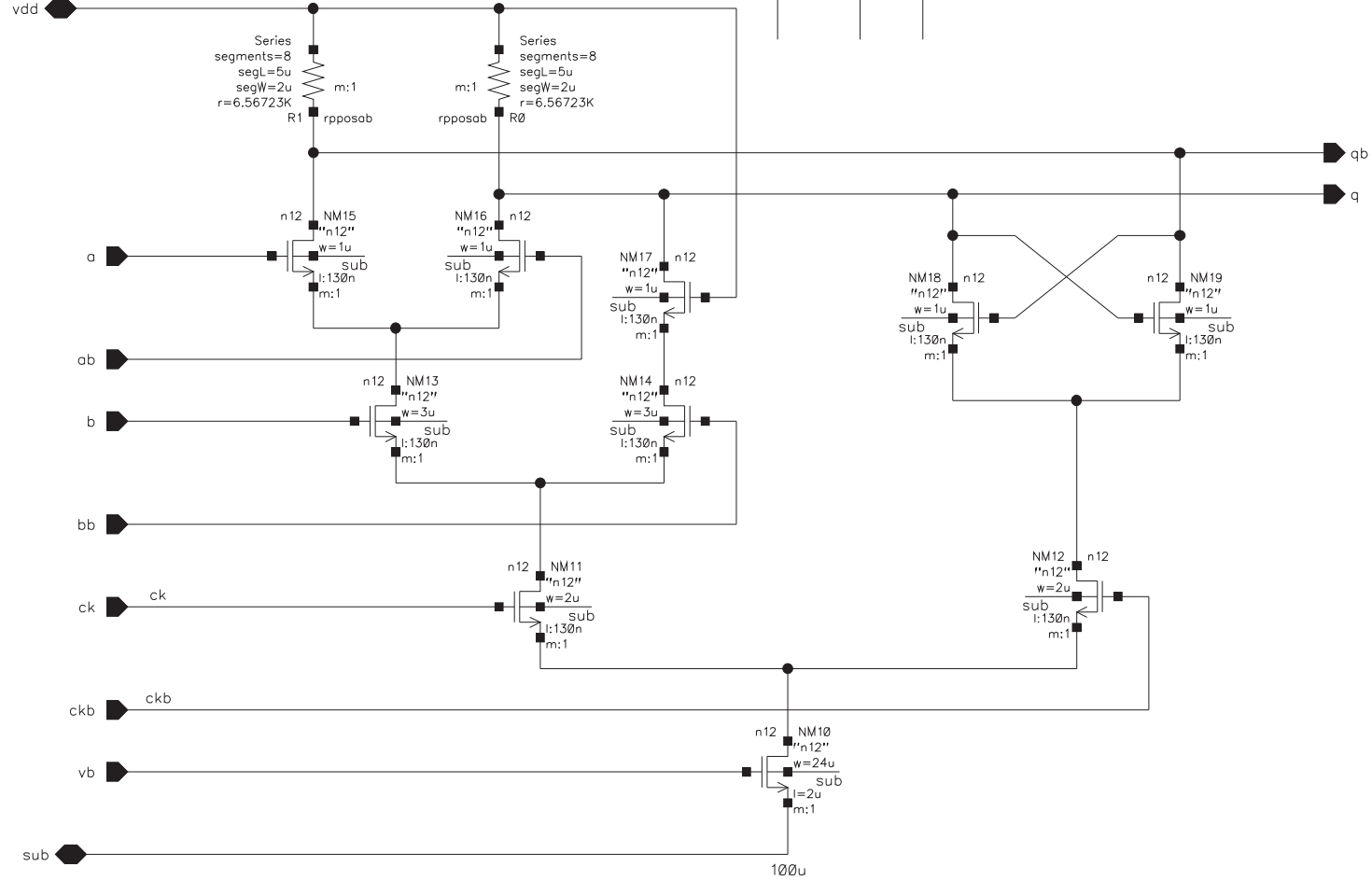

Layout Notes:

1. Match NM11/NM12, NM13/NM14, NM18/NM19, NM15/NM16.
2. Do careful layout floor plan to minimize parasitic routine cap is very important.

UPDATED	Oct 25 01:50:07 2006		
DRAWN	cml_and_latch_2g		
CHECKED			
CHECKED	SIZE	CAGE NO.	DWG NO.
ISSUED	A		
	SCALE		SHEET OF

REVISIONS				
ZONE	REV	DESCRIPTION	DATE	APPROVED

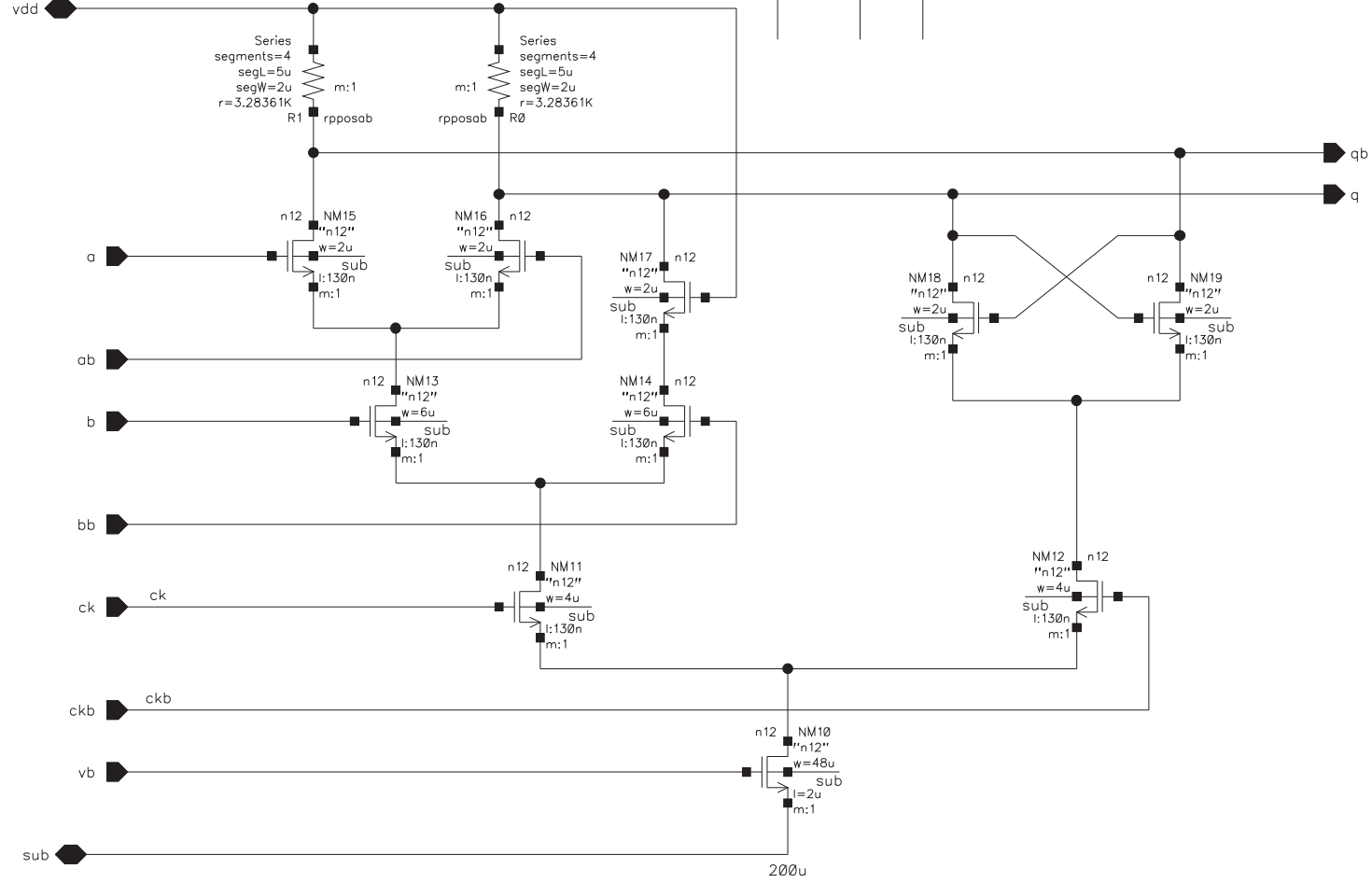

Layout Notes:
 1. Match NM11/NM12, NM13/NM14, NM18/NM19, NM15/NM16.
 2. Do careful layout floor plan to minize parasitic routine cap is very important.

UPDATED	Oct 25 01:50:07 2006		
DRAWN	cml_and_latch_2g		
CHECKED			
CHECKED	SIZE	CAGE NO.	DWG NO.
ISSUED	A		
	SCALE		SHEET OF

REVISIONS				
ZONE	REV	DESCRIPTION	DATE	APPROVED

Layout Notes:
1. Minimize routing parasitics.

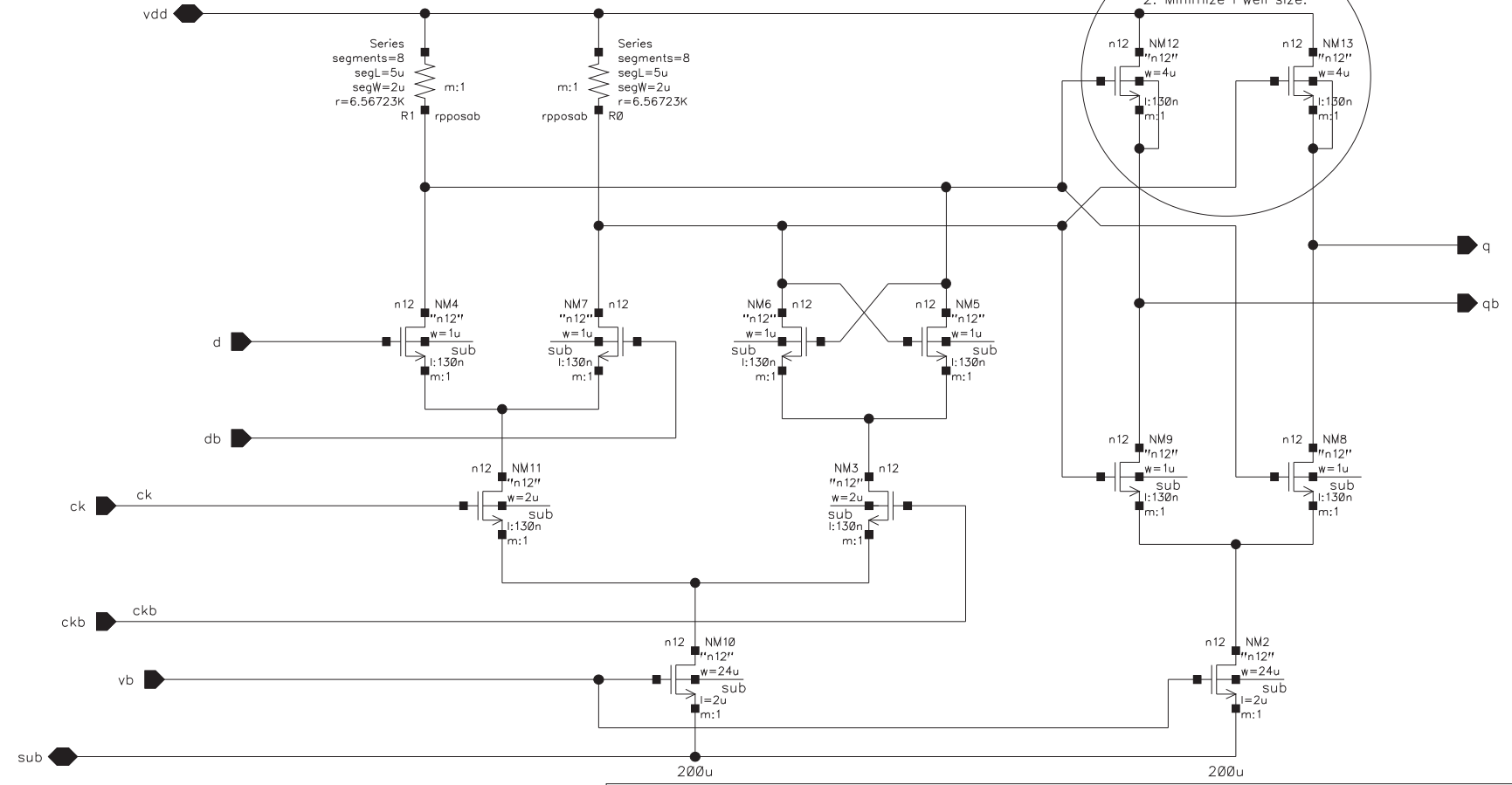
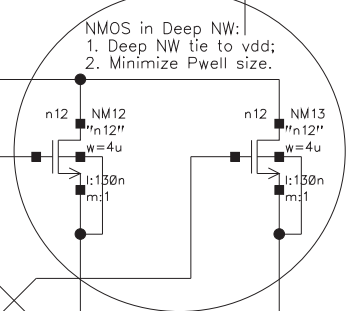

UPDATED			
Oct 25 01:50:07 2006			
DRAWN			
CHECKED			
CHECKED	SIZE	CAGE NO.	REV
ISSUED	SCALE	DWG NO.	SHEET OF

REVISIONS				
ZONE	REV	DESCRIPTION	DATE	APPROVED

Layout Notes:
1. Minimize routing parasitics.

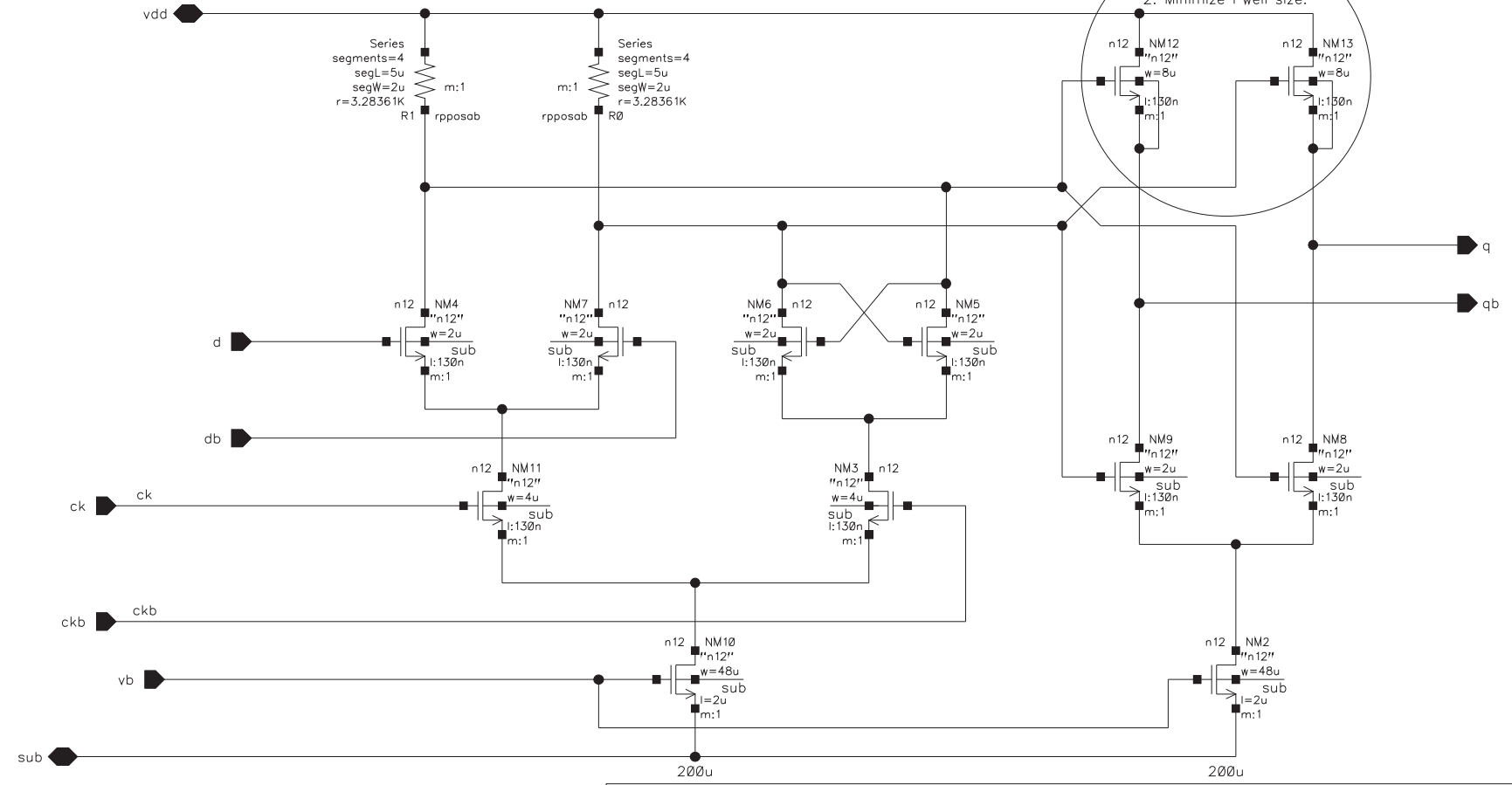
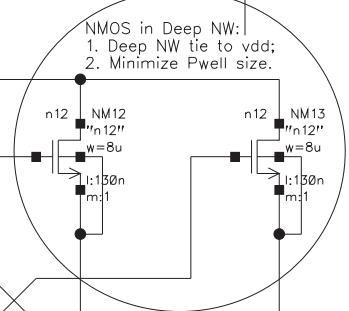

UPDATED			
Oct 25 01:50:07 2006			
DRAWN			
CHECKED			
CHECKED	SIZE	CAGE NO.	DWG NO.
ISSUED	A		
	SCALE		SHEET OF

REVISIONS				
ZONE	REV	DESCRIPTION	DATE	APPROVED

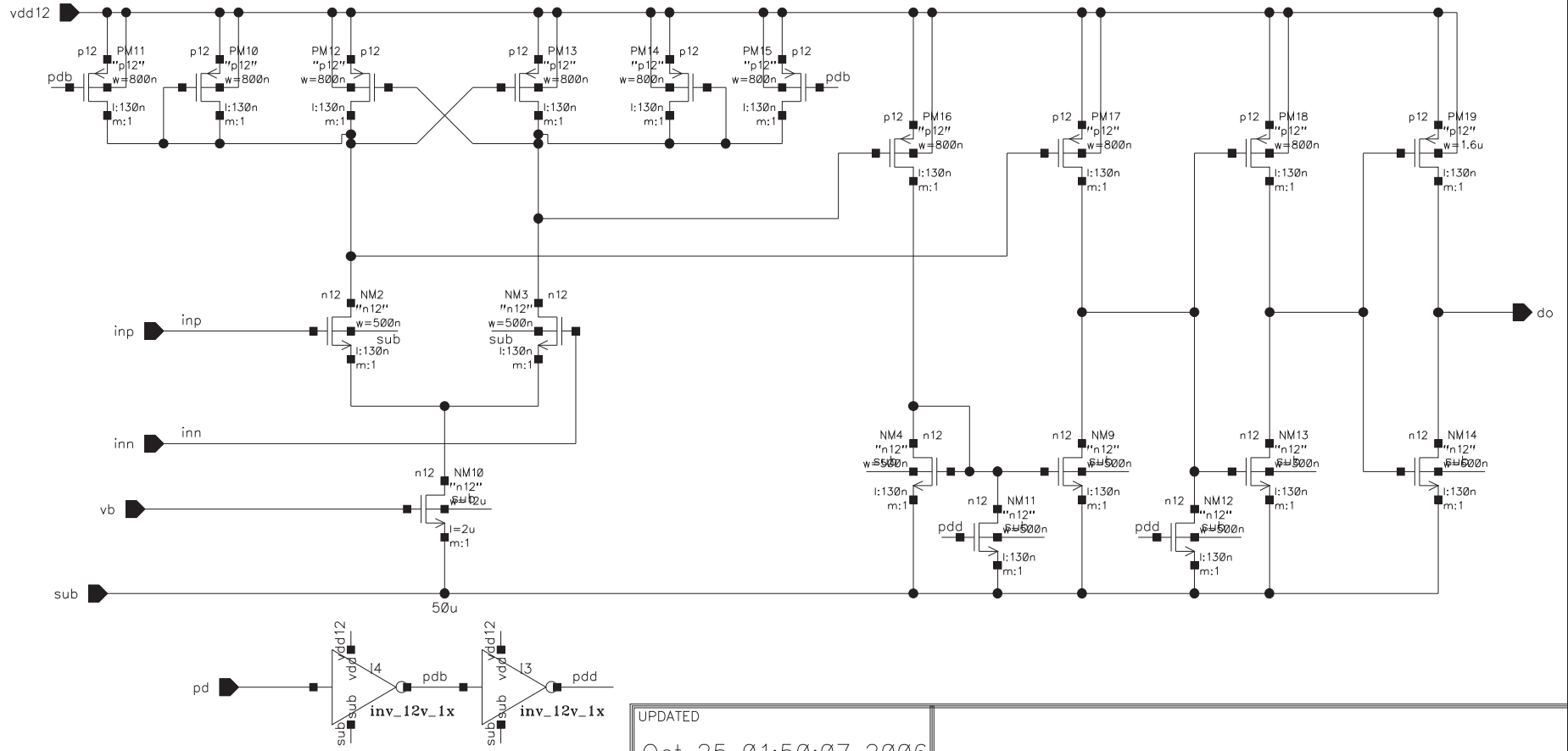

Layout Notes:

- Match: NM3/NM4, PM1/PM0/PM2/PM3, PM4/PM5, NM0/NM1 (interdigitize)

UPDATED

Oct 25 01:50:07 2006

DRAWN

CHECKED

CHECKED

ISSUED

SIZE	CAGE NO.	DWG NO.	REV
A			
SCALE	SHEET		OF

REVISIONS				
ZONE	REV	DESCRIPTION	DATE	APPROVED

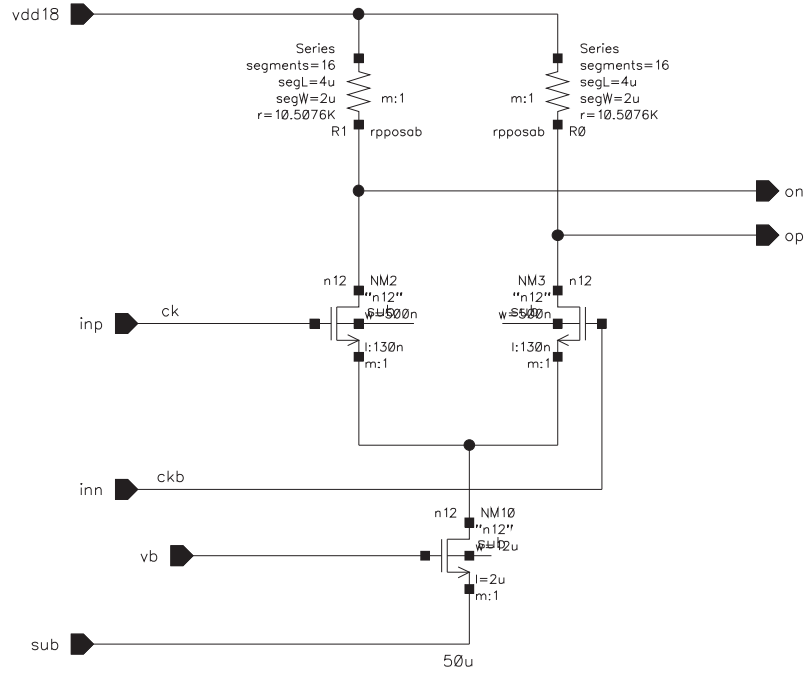

UPDATED				
Oct 25 01:50:07 2006				
DRAWN				
CHECKED				
CHECKED	SIZE	CAGE NO.	DWG NO.	REV
ISSUED	A			
	SCALE		SHEET	OF

REVISIONS				
ZONE	REV	DESCRIPTION	DATE	APPROVED

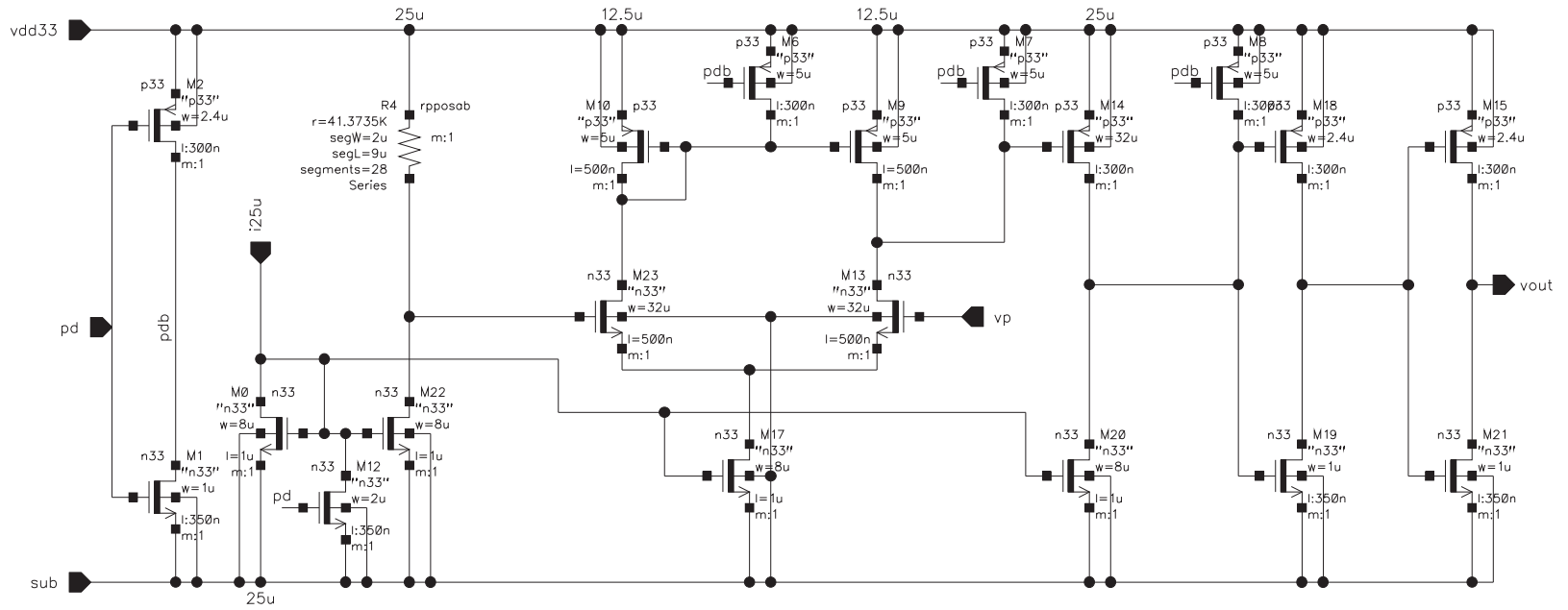

UPDATED	Oct 25 01:50:08 2006			
DRAWN	compn			
CHECKED				
CHECKED	SIZE	CAGE NO.	DWG NO.	REV
ISSUED	A			
	SCALE	SHEET 1 OF 1		

REVISIONS				
ZONE	REV	DESCRIPTION	DATE	APPROVED

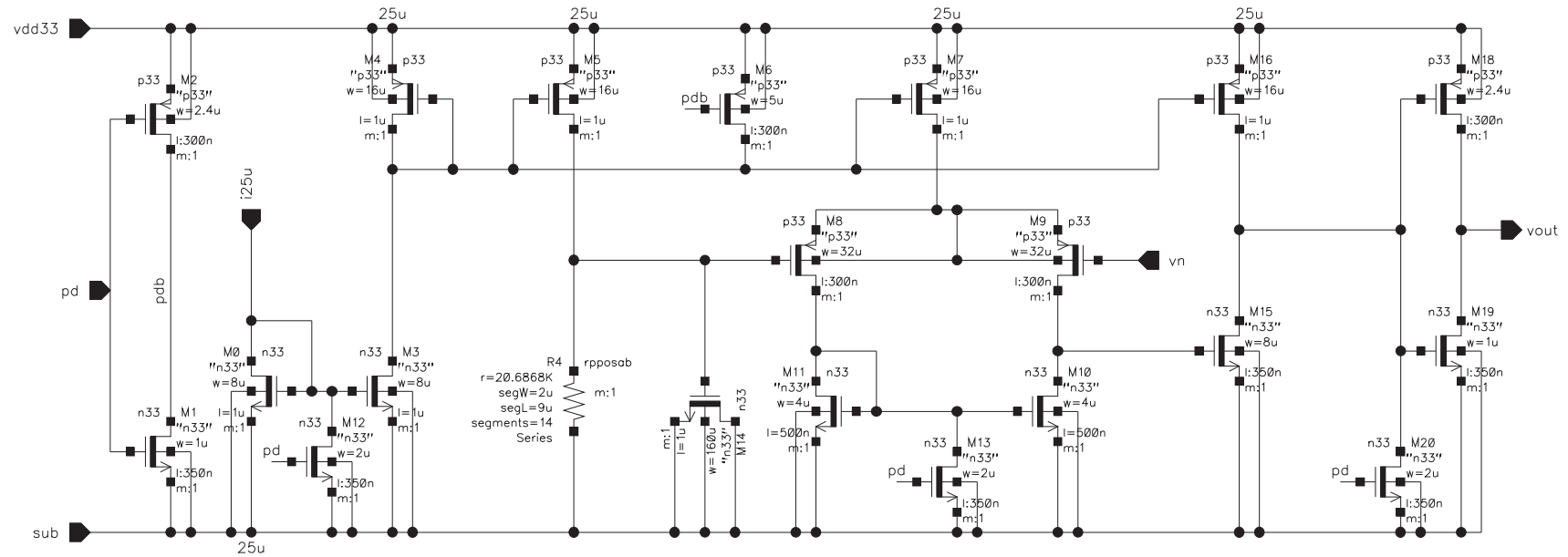

UPDATED				
Oct 25 01:50:08 2006				
DRAWN	compp			
CHECKED				
CHECKED	SIZE	CAGE NO.	DWG NO.	REV
ISSUED	A			
	SCALE		SHEET	1 OF 1

REVISIONS				
ZONE	REV	DESCRIPTION	DATE	APPROVED

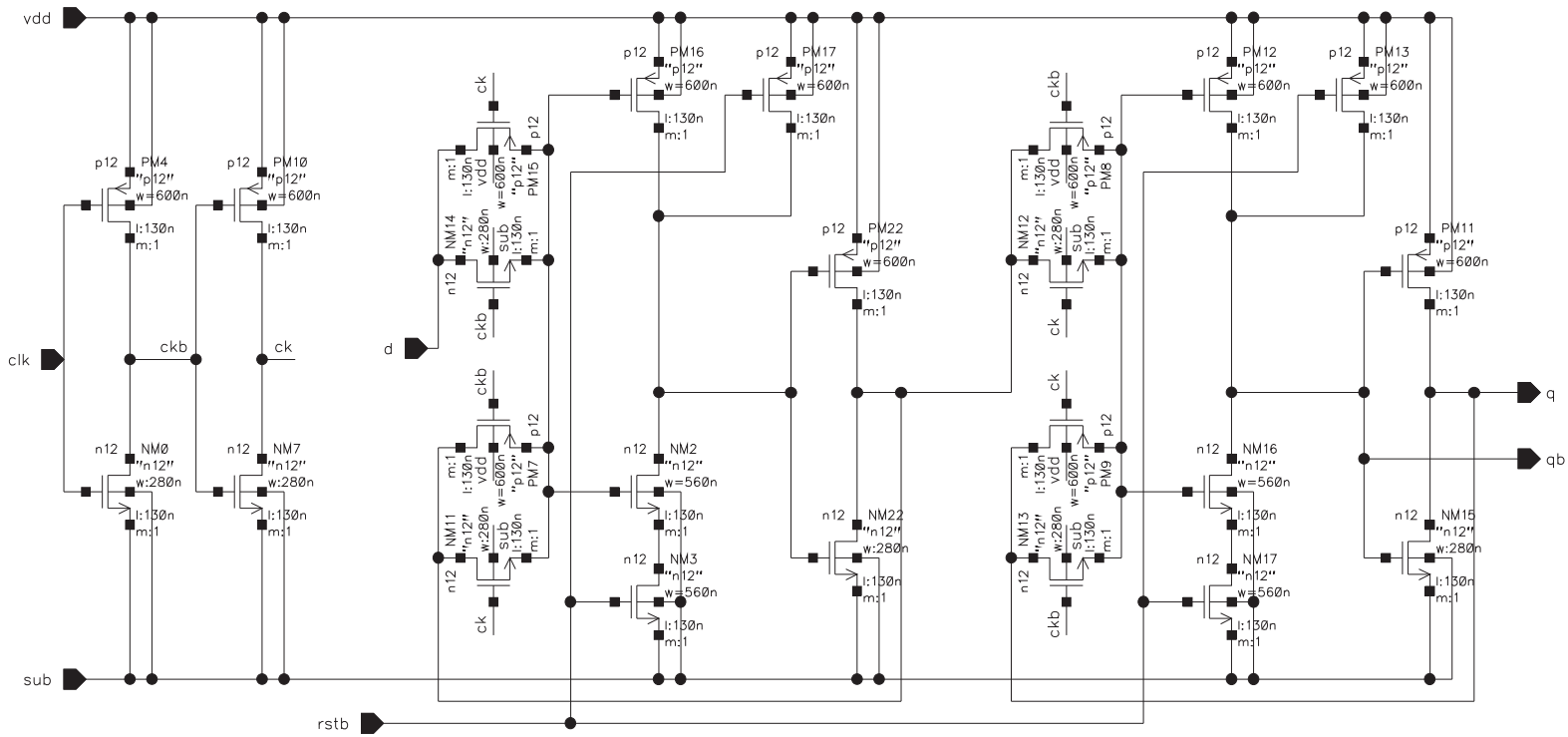

UPDATED				
Oct 25 01:50:07 2006				
DRAWN	d_ffr			
CHECKED				
CHECKED	SIZE	CAGE NO.	DWG NO.	REV
ISSUED	A			
	SCALE			SHEET 1 OF 1

REVISIONS				
ZONE	REV	DESCRIPTION	DATE	APPROVED

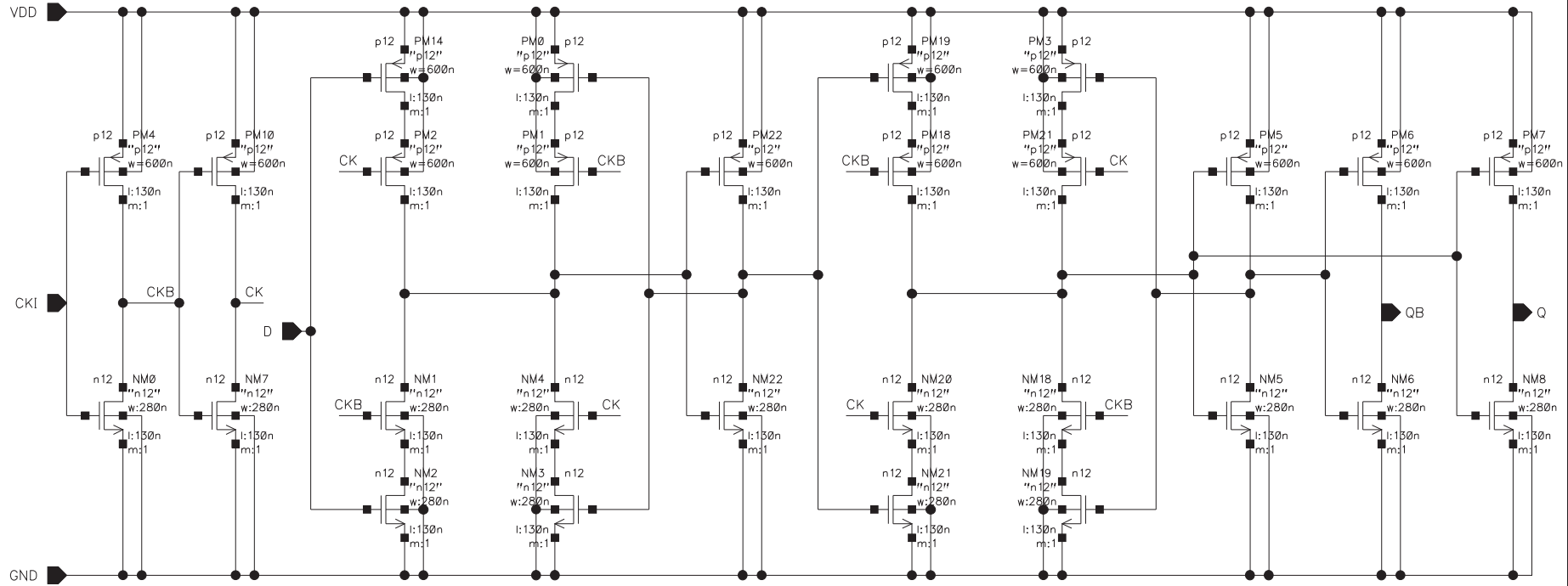

Design Notes:
 1. CK and CKB rise/fall time < 0.3nS in TT.

UPDATED	Oct 25 01:50:07 2006			
DRAWN	dff_12vqb			
CHECKED				
CHECKED	SIZE	CAGE NO.	DWG NO.	REV
ISSUED	A			
	SCALE		SHEET	OF

REVISIONS				
ZONE	REV	DESCRIPTION	DATE	APPROVED

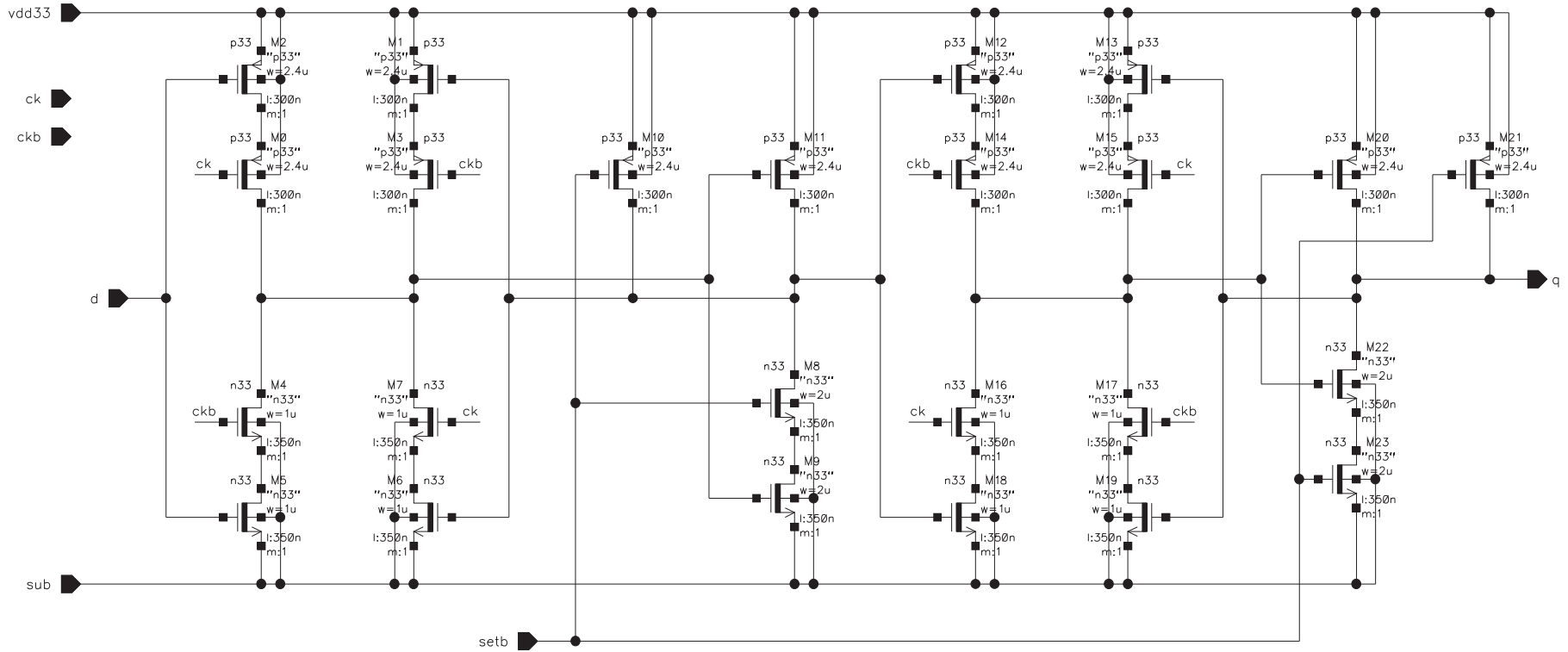

UPDATED				
Oct 25 01:50:08 2006				
DRAWN				
CHECKED				
CHECKED	SIZE	CAGE NO.	DWG NO.	REV
ISSUED	A			
	SCALE		SHEET	1 OF 1

REVISIONS				
ZONE	REV	DESCRIPTION	DATE	APPROVED

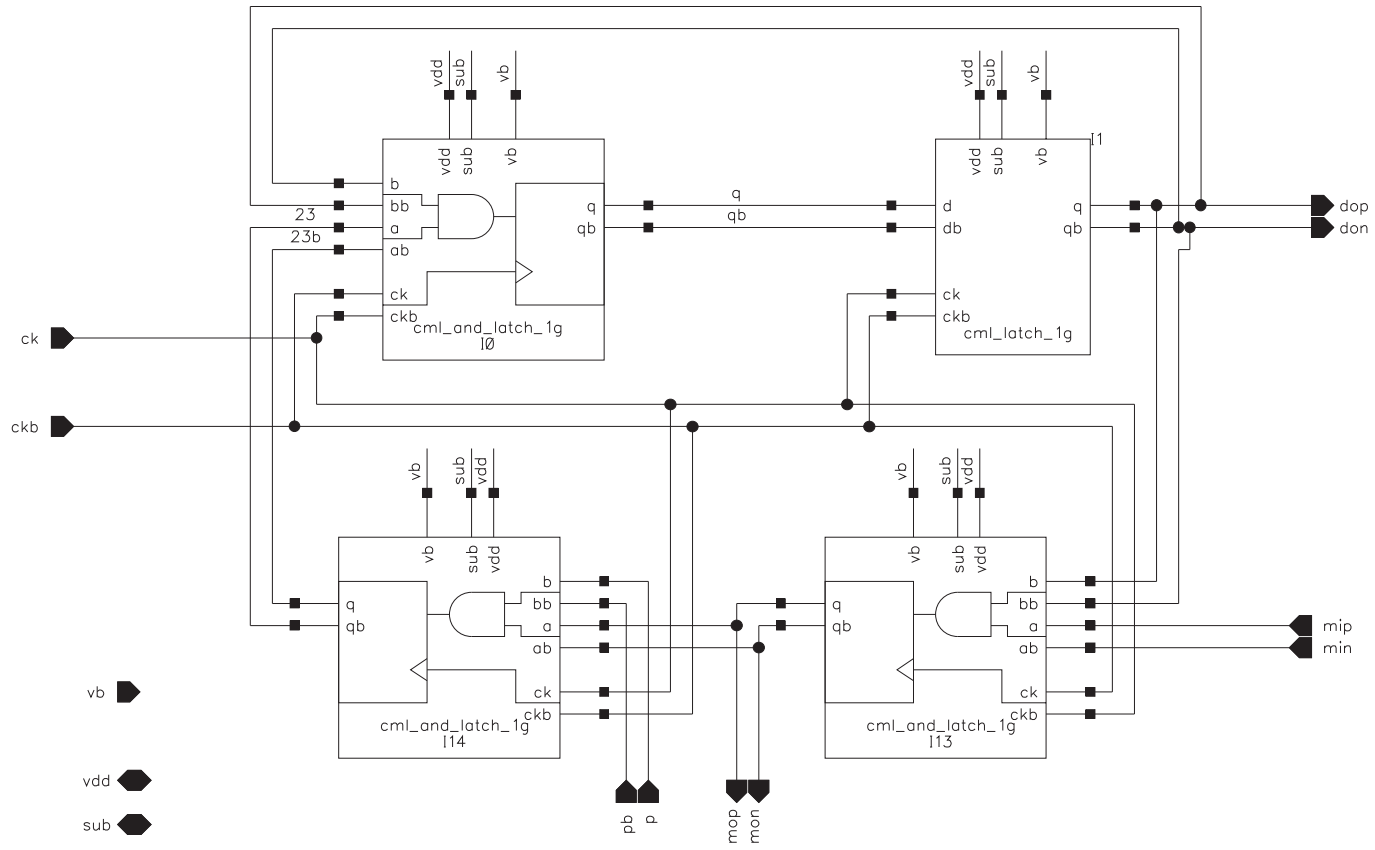

UPDATED	Oct 25 01:50:07 2006		
DRAWN	div_23_1g		
CHECKED			
CHECKED	SIZE	CAGE NO.	DWG NO.
ISSUED	A		
	SCALE		SHEET OF

REVISIONS				
ZONE	REV	DESCRIPTION	DATE	APPROVED

Layout Notes:

. Do careful layout floor plan to minize parasitic routine cap is very important.

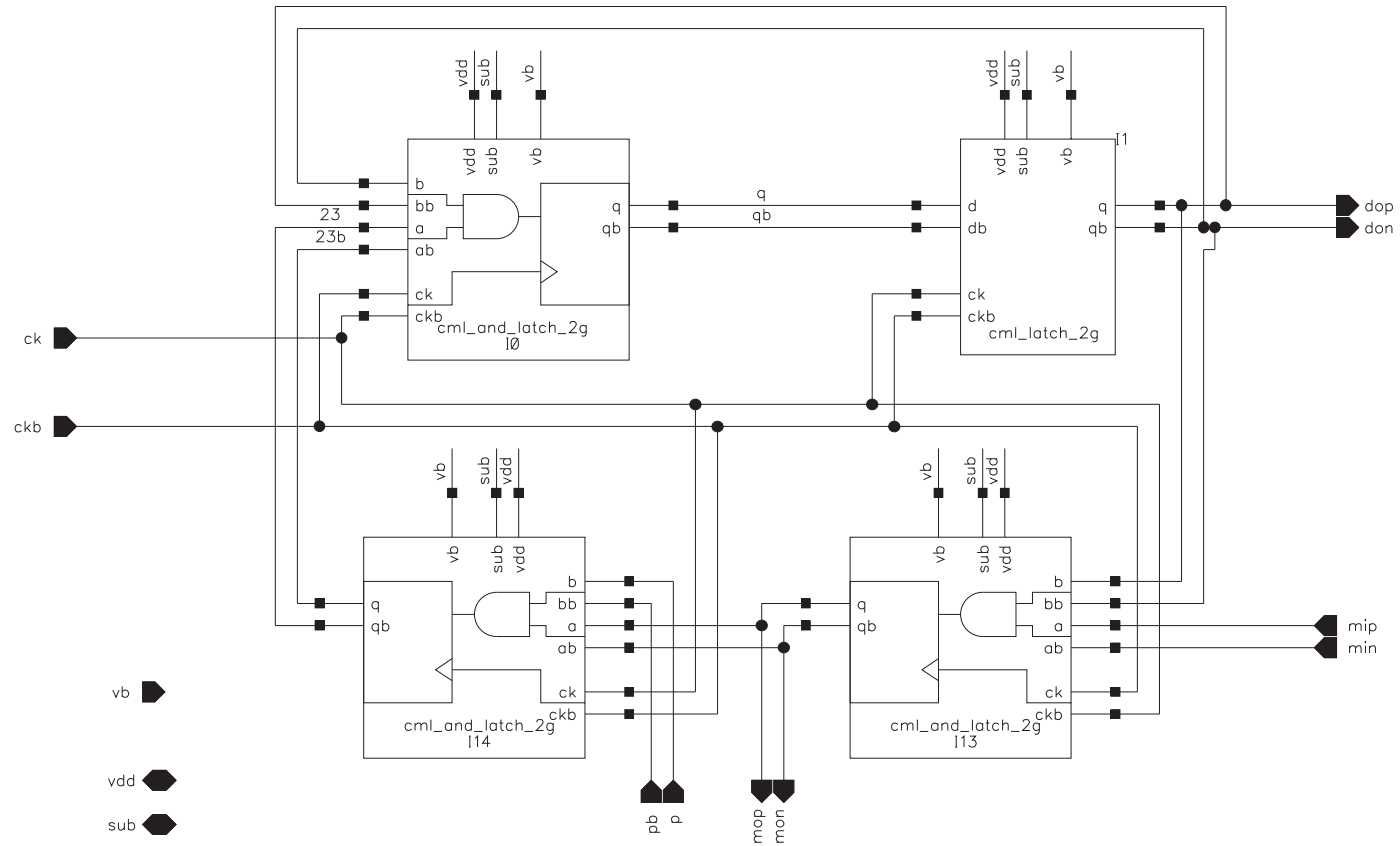

UPDATED	Oct 25 01:50:07 2006		
DRAWN	div_23_2g		
CHECKED			
CHECKED	SIZE	CAGE NO.	DWG NO.
ISSUED	A		
	SCALE		SHEET OF

REVISIONS				
ZONE	REV	DESCRIPTION	DATE	APPROVED

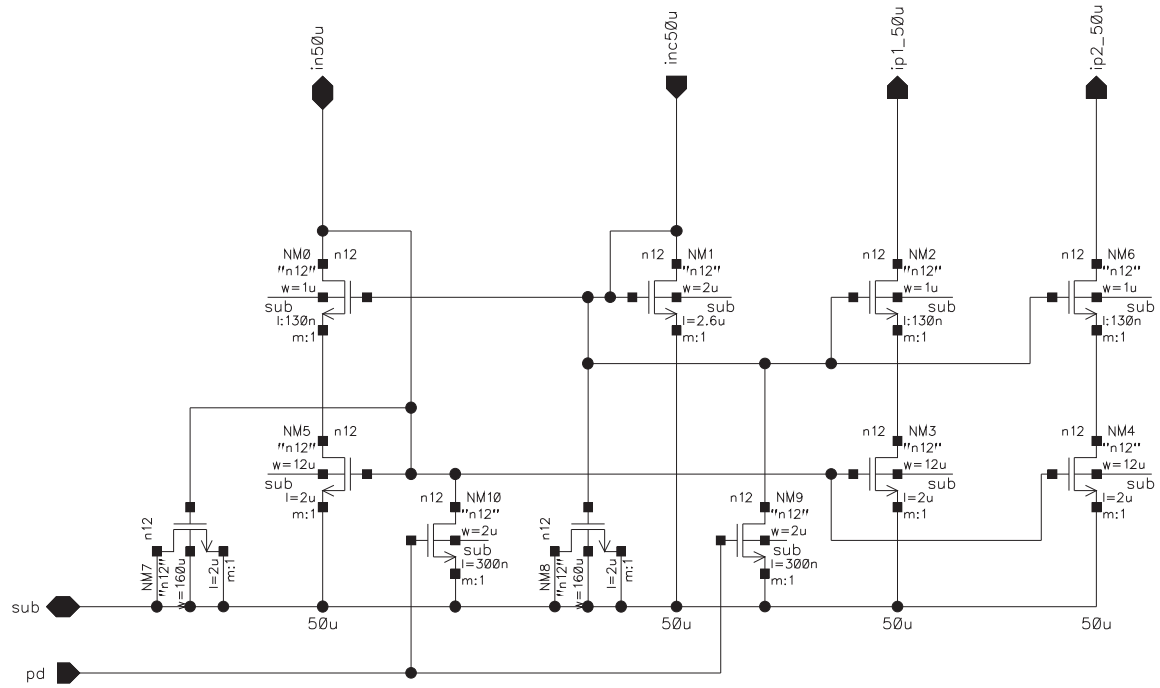

Layout Notes:

Match: NM3/NM4/NM5, NM0/NM2/NM6

UPDATED	Oct 25 01:50:07 2006		
DRAWN	div_bias		
CHECKED			
CHECKED	SIZE	CAGE NO.	DWG NO.
ISSUED	A		
	SCALE		SHEET OF

REVISIONS				
ZONE	REV	DESCRIPTION	DATE	APPROVED

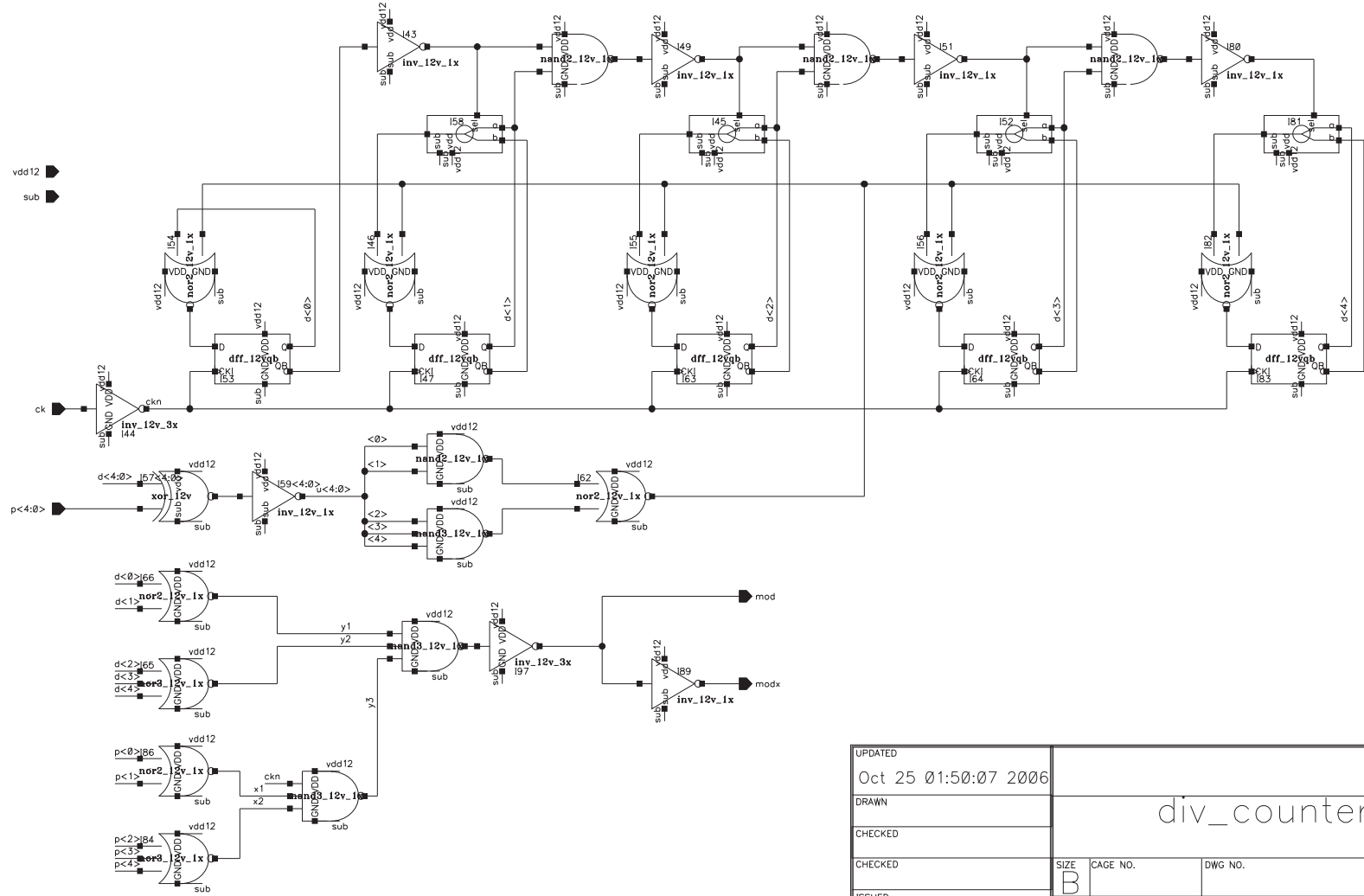

UPDATED	Oct 25 01:50:07 2006			
DRAWN	div_counter			
CHECKED				
CHECKED	SIZE B	CAGE NO.	DWG NO.	REV
ISSUED	SCALE			SHEET 1 OF 1

REVISIONS				
ZONE	REV	DESCRIPTION	DATE	APPROVED

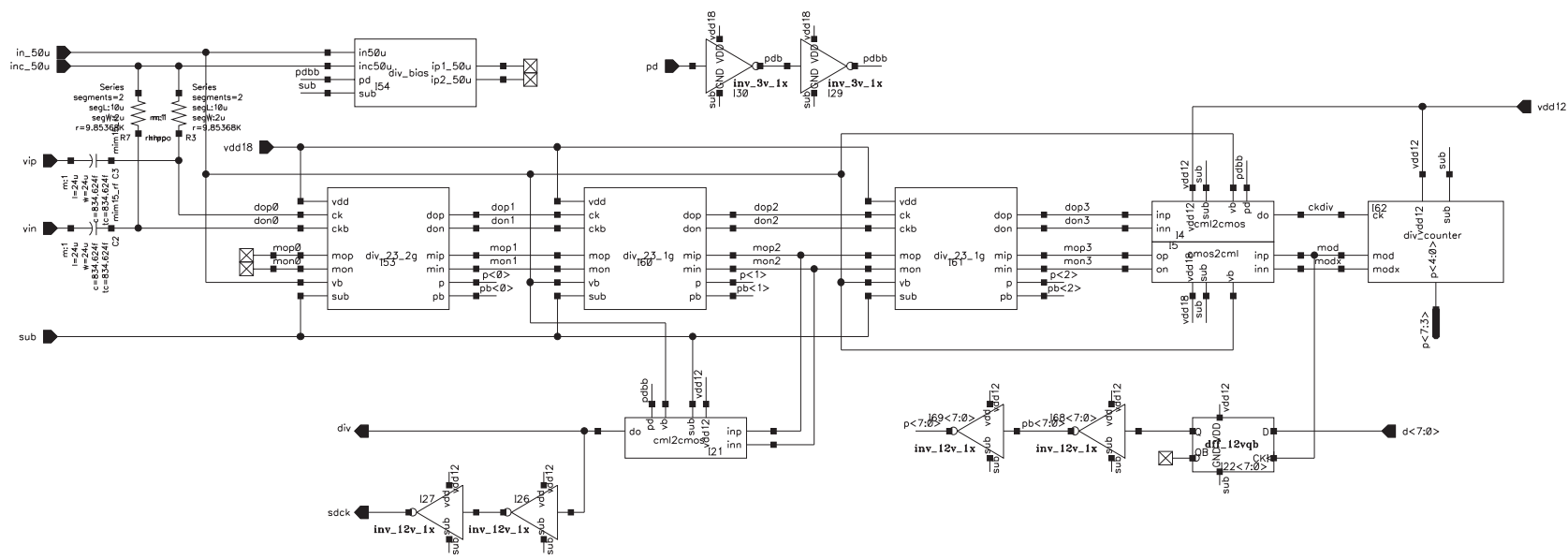

UPDATED	Oct 25 01:50:07 2006			
DRAWN	div_top			
CHECKED				
CHECKED	SIZE	CAGE NO.	DWG NO.	REV
ISSUED	B			
	SCALE		SHEET	OF

REVISIONS				
ZONE	REV	DESCRIPTION	DATE	APPROVED

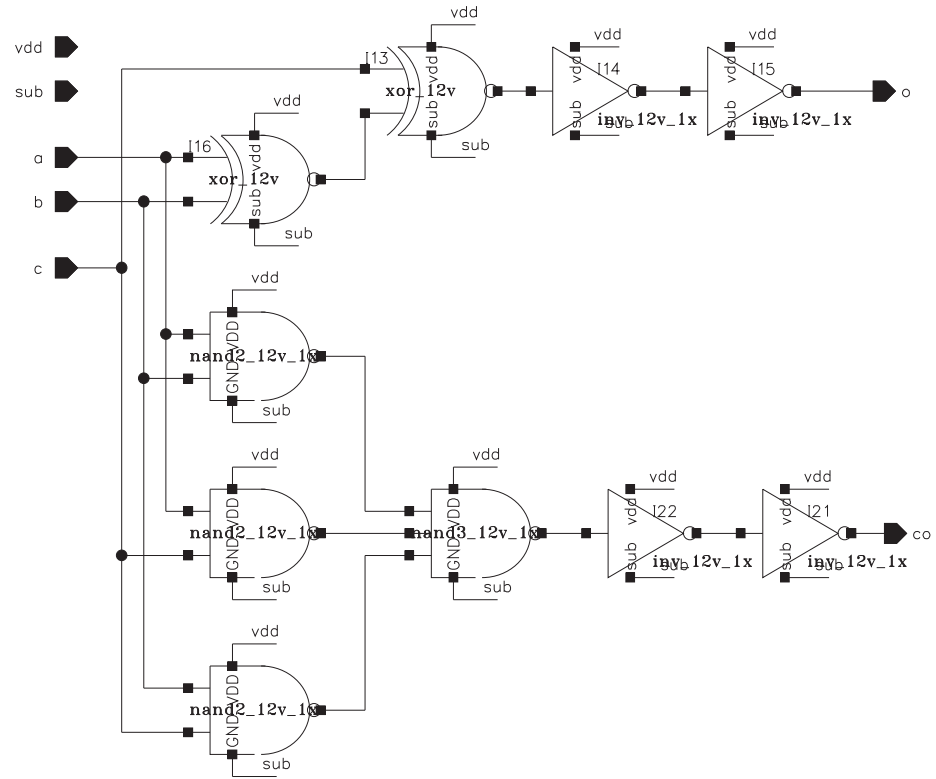

UPDATED			
Oct 25 01:50:07 2006			
DRAWN			
CHECKED			
CHECKED	SIZE	CAGE NO.	DWG NO.
ISSUED	A		
	SCALE		SHEET 1 OF 1

full_adder			

REVISIONS				
ZONE	REV	DESCRIPTION	DATE	APPROVED

This block is for simulation only.

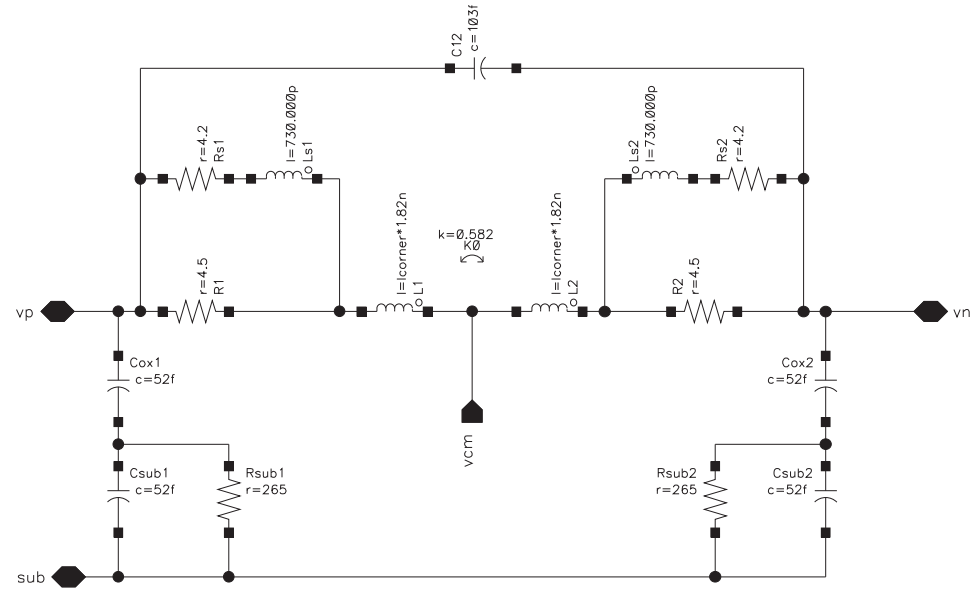

5 turns with inner radius R=66u, W=15u, S=2u.

UPDATED	Oct 25 01:50:08 2006			
DRAWN	ind_vco1			
CHECKED				
CHECKED	SIZE	CAGE NO.	DWG NO.	REV
ISSUED	A			
	SCALE		SHEET	1 OF 1

REVISIONS				
ZONE	REV	DESCRIPTION	DATE	APPROVED

This block is for simulation only.

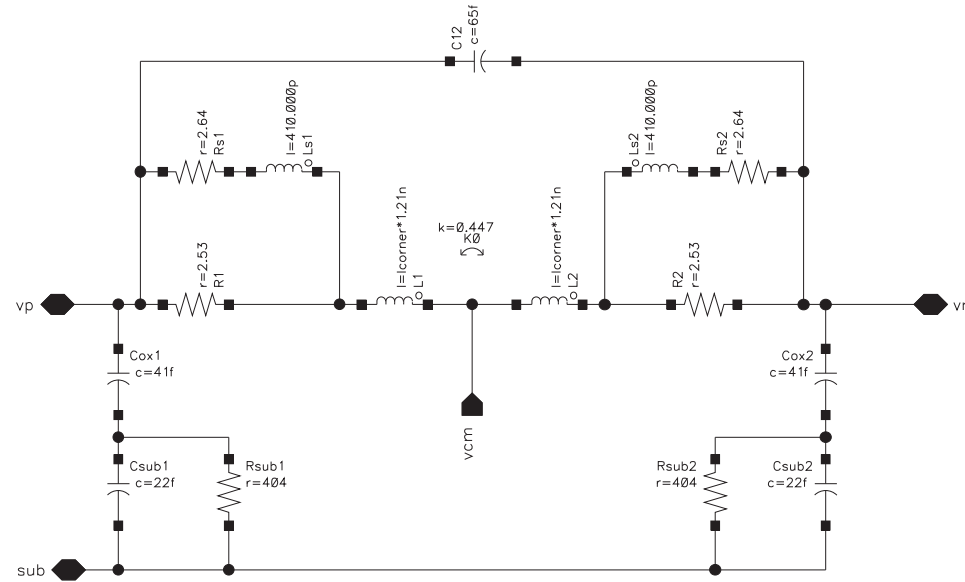

3 turns with inner radius $R=107\mu$, $W=15\mu$, $S=2\mu$.

UPDATED	Oct 25 01:50:08 2006			
DRAWN	ind_vco			
CHECKED				
CHECKED	SIZE	CAGE NO.	DWG NO.	REV
ISSUED	A			
	SCALE		SHEET	1 OF 1

REVISIONS				
ZONE	REV	DESCRIPTION	DATE	APPROVED

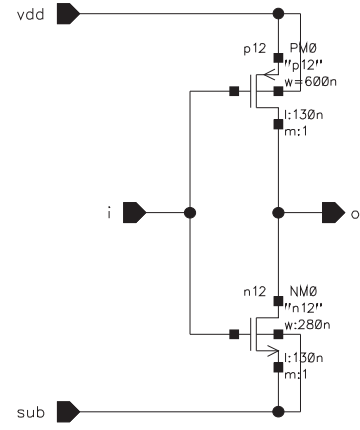

UPDATED				
Oct 25 01:50:07 2006				
DRAWN				
CHECKED				
CHECKED	SIZE	CAGE NO.	DWG NO.	REV
ISSUED	A			
	SCALE		SHEET	OF

inv_12v_1x

REVISIONS				
ZONE	REV	DESCRIPTION	DATE	APPROVED

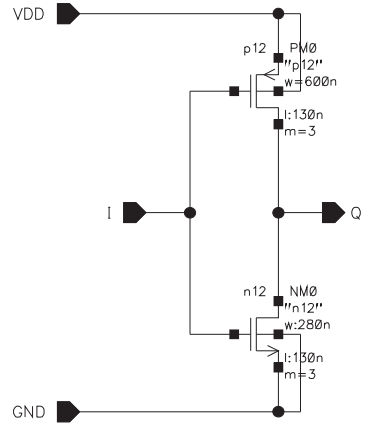

UPDATED				
Oct 25 01:50:07 2006				
DRAWN				
CHECKED				
CHECKED	SIZE	CAGE NO.	DWG NO.	REV
ISSUED	A			
	SCALE		SHEET	OF

inv_12v_1x



CAGE NO.	DWG NO.	SH	REV
----------	---------	----	-----

REVISIONS				
ZONE	REV	DESCRIPTION	DATE	APPROVED

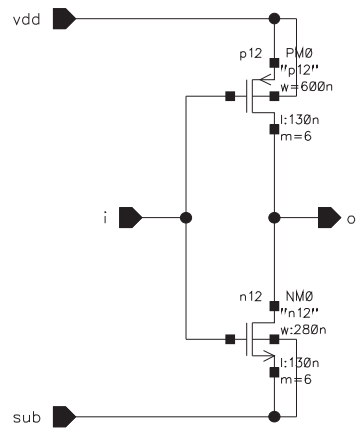

UPDATED				
Oct 25 01:50:07 2006				
DRAWN	inv_12v_6x			
CHECKED				
CHECKED	SIZE	CAGE NO.	DWG NO.	REV
	A			
ISSUED	SCALE		SHEET	OF



REVISIONS				
ZONE	REV	DESCRIPTION	DATE	APPROVED

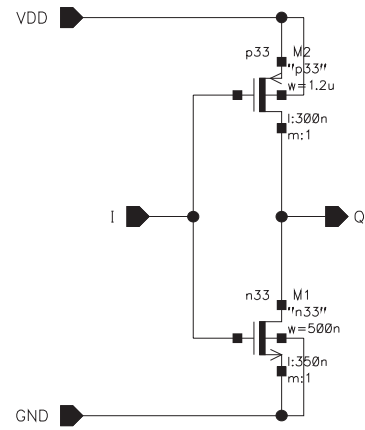

UPDATED				
Oct 25 01:50:08 2006				
DRAWN	inv_3v_05x			
CHECKED				
CHECKED	SIZE	CAGE NO.	DWG NO.	REV
ISSUED	A			
	SCALE		SHEET	OF

REVISIONS				
ZONE	REV	DESCRIPTION	DATE	APPROVED

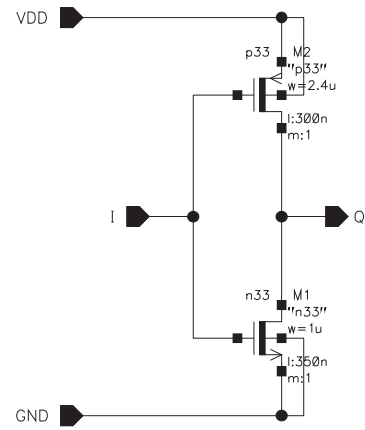

UPDATED				
Oct 25 01:50:07 2006				
DRAWN				
CHECKED				
CHECKED	SIZE	CAGE NO.	DWG NO.	REV
ISSUED	A			
	SCALE		SHEET	OF

inv_3v_1x

REVISIONS				
ZONE	REV	DESCRIPTION	DATE	APPROVED

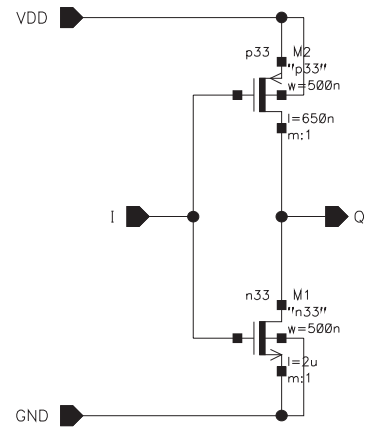

UPDATED				
Oct 25 01:50:08 2006				
DRAWN	inv_3v_05x			
CHECKED				
CHECKED	SIZE	CAGE NO.	DWG NO.	REV
ISSUED	A			
	SCALE		SHEET	OF

REVISIONS				
ZONE	REV	DESCRIPTION	DATE	APPROVED

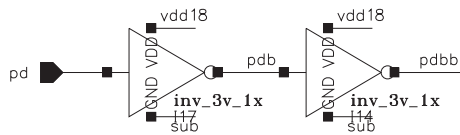
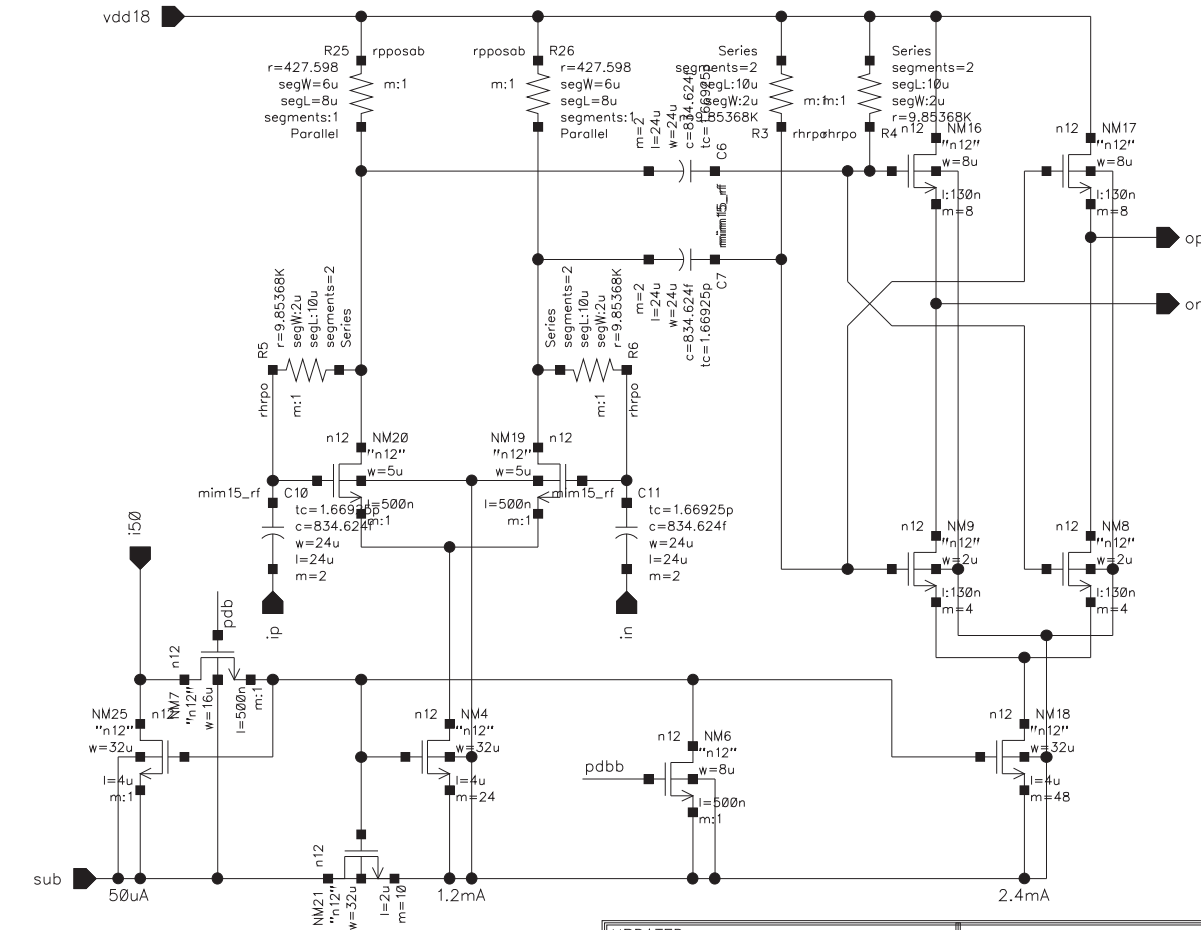

UPDATED	Oct 25 01:50:08 2006		
DRAWN	lo_lband_buf		
CHECKED			
CHECKED	SIZE	CAGE NO.	DWG NO.
ISSUED	A		
	SCALE		SHEET 1 OF 1

REVISIONS				
ZONE	REV	DESCRIPTION	DATE	APPROVED

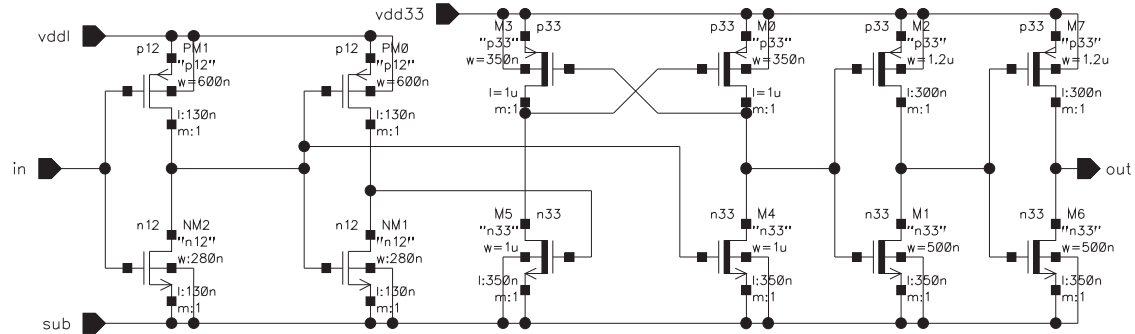

UPDATED				
Oct 25 01:50:07 2006				
DRAWN	logic_12h			
CHECKED				
CHECKED	SIZE	CAGE NO.	DWG NO.	REV
ISSUED	A			
	SCALE		SHEET	OF

REVISIONS				
ZONE	REV	DESCRIPTION	DATE	APPROVED

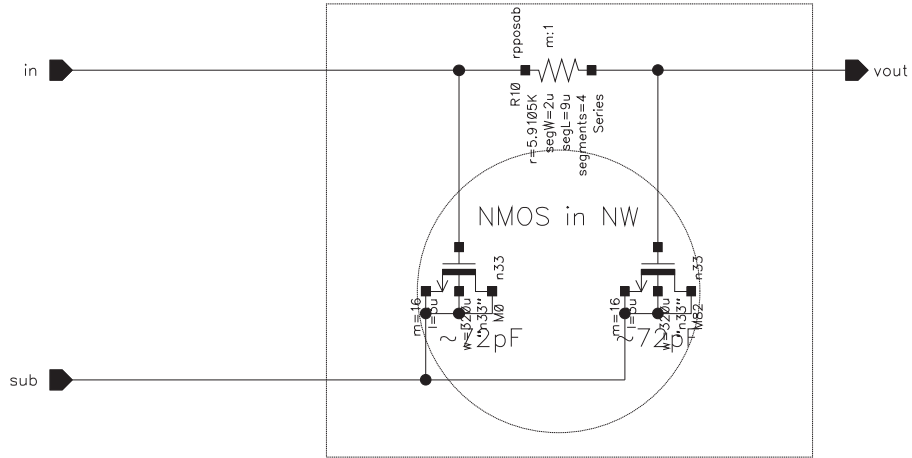

UPDATED	Oct 25 01:50:07 2006			
DRAWN	PLL Loop Filter			
CHECKED				
CHECKED	SIZE	CAGE NO.	DWG NO.	REV
ISSUED	A			
	SCALE		SHEET	1 OF 1

REVISIONS				
ZONE	REV	DESCRIPTION	DATE	APPROVED

Design Notes:
 1. When $V_{in} > 550\text{mV}$ or $< v_{dd}-1.1\text{V}$, $det=1$, loop is locked.
 Else, $det=0$, indicating out of lock.
 2. When in PD, $det=0$.

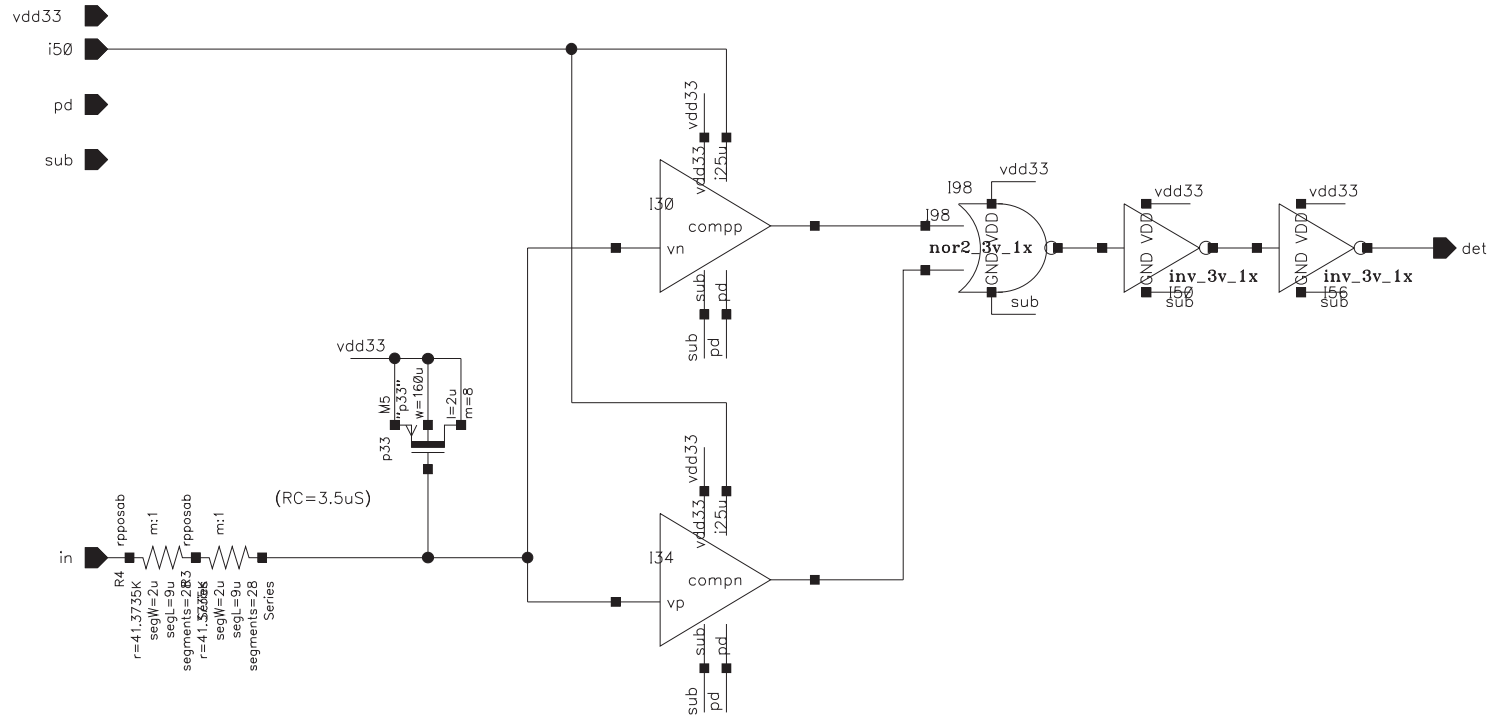

UPDATED	Oct 25 01:50:08 2006		
DRAWN	loopcomp		
CHECKED			
CHECKED	SIZE	CAGE NO.	DWG NO.
ISSUED	A		
	SCALE		SHEET 1 OF 1

REVISIONS				
ZONE	REV	DESCRIPTION	DATE	APPROVED

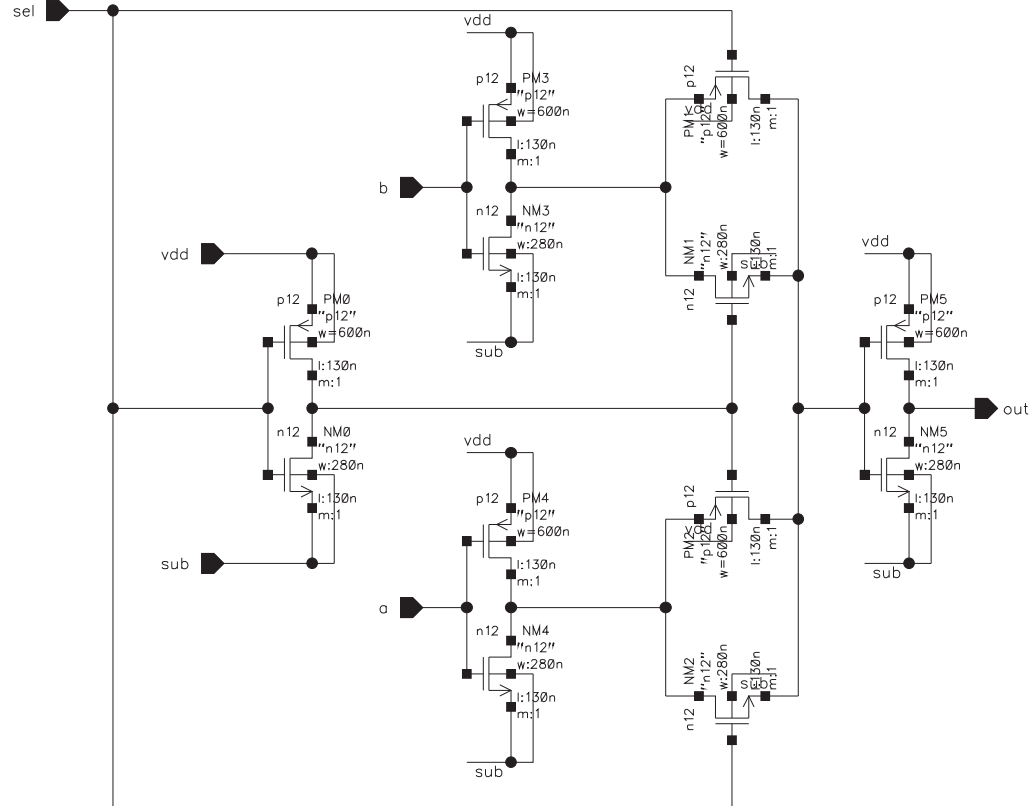

Design Notes:
 1. SEL=1: select A; SEL=0: select B.

UPDATED	Oct 25 01:50:07 2006			
DRAWN	mux2_12v			
CHECKED				
CHECKED	SIZE	CAGE NO.	DWG NO.	REV
ISSUED	A			
	SCALE		SHEET	1 OF 1

REVISIONS				
ZONE	REV	DESCRIPTION	DATE	APPROVED

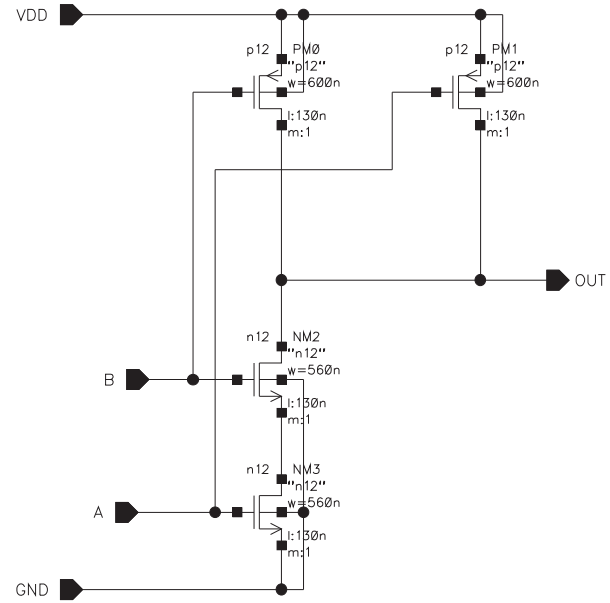

UPDATED	
Oct 25 01:50:07 2006	
DRAWN	
CHECKED	
CHECKED	
ISSUED	

nand2_12v_1x			
SIZE	CAGE NO.	DWG NO.	REV
A			
SCALE		SHEET	OF

REVISIONS				
ZONE	REV	DESCRIPTION	DATE	APPROVED

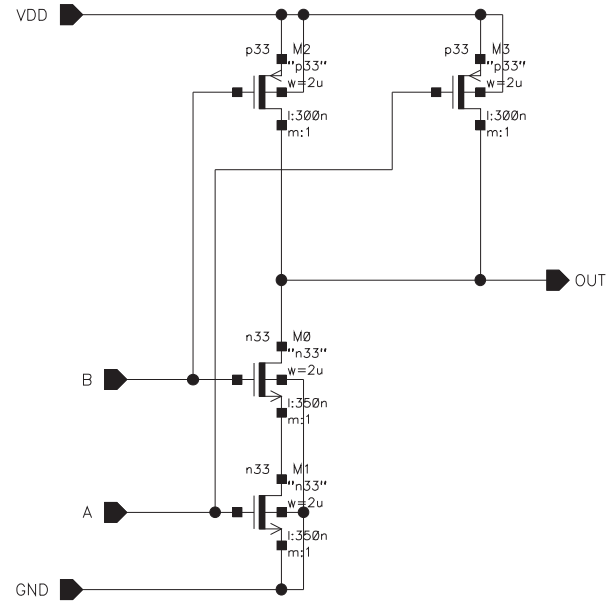

UPDATED				
Oct 25 01:50:08 2006				
DRAWN				
CHECKED				
CHECKED				
ISSUED	SIZE	CAGE NO.	DWG NO.	REV
	A			
	SCALE		SHEET	OF

nand2_3v_1x

REVISIONS				
ZONE	REV	DESCRIPTION	DATE	APPROVED

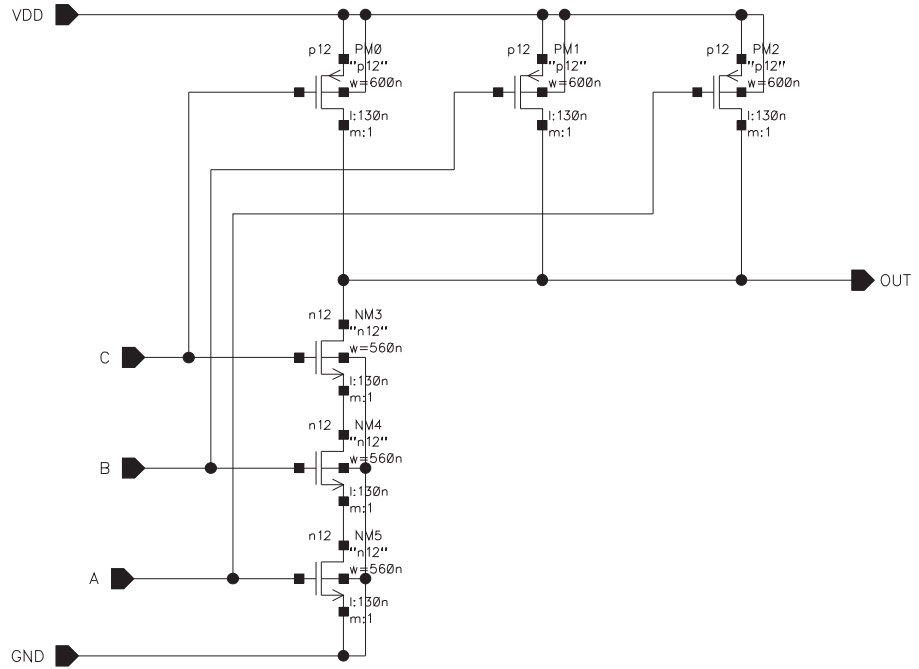

UPDATED				
Oct 25 01:50:07 2006				
DRAWN				
CHECKED				
CHECKED	SIZE	CAGE NO.	DWG NO.	REV
ISSUED	A			
	SCALE		SHEET	OF

nand3_12v_1x

REVISIONS				
ZONE	REV	DESCRIPTION	DATE	APPROVED

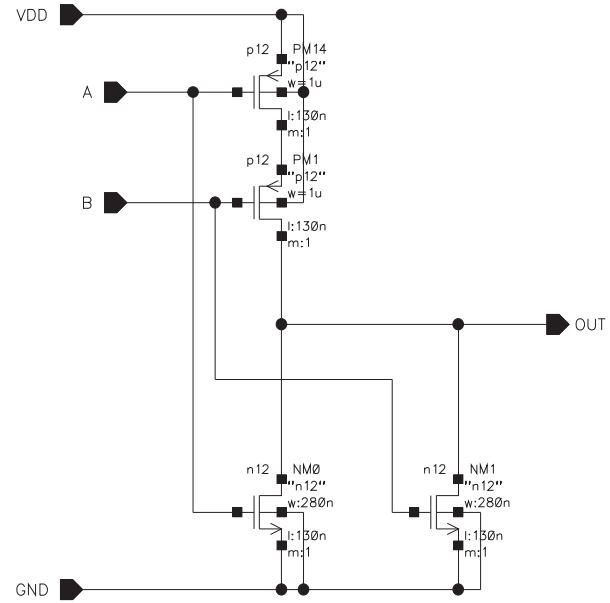

UPDATED				
Oct 25 01:50:07 2006				
DRAWN	nor2_12v_1x			
CHECKED				
CHECKED	SIZE	CAGE NO.	DWG NO.	REV
ISSUED	A			
	SCALE		SHEET	OF

REVISIONS				
ZONE	REV	DESCRIPTION	DATE	APPROVED

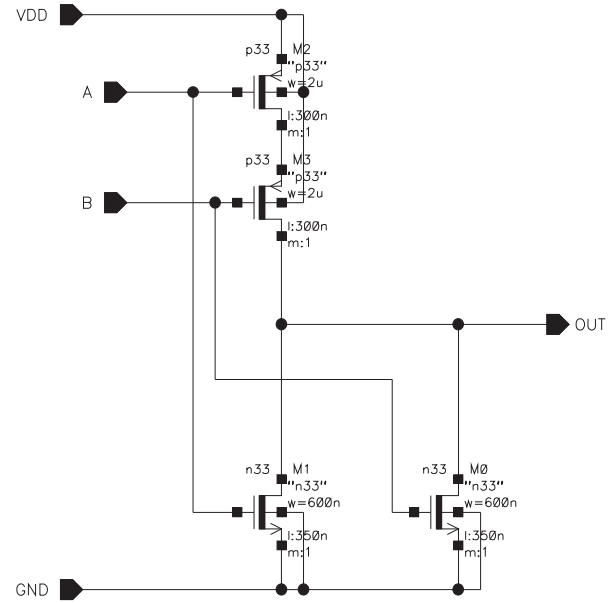

UPDATED				
Oct 25 01:50:07 2006				
DRAWN	nor2_3v_1x			
CHECKED				
CHECKED	SIZE	CAGE NO.	DWG NO.	REV
ISSUED	A			
	SCALE		SHEET	OF

REVISIONS				
ZONE	REV	DESCRIPTION	DATE	APPROVED

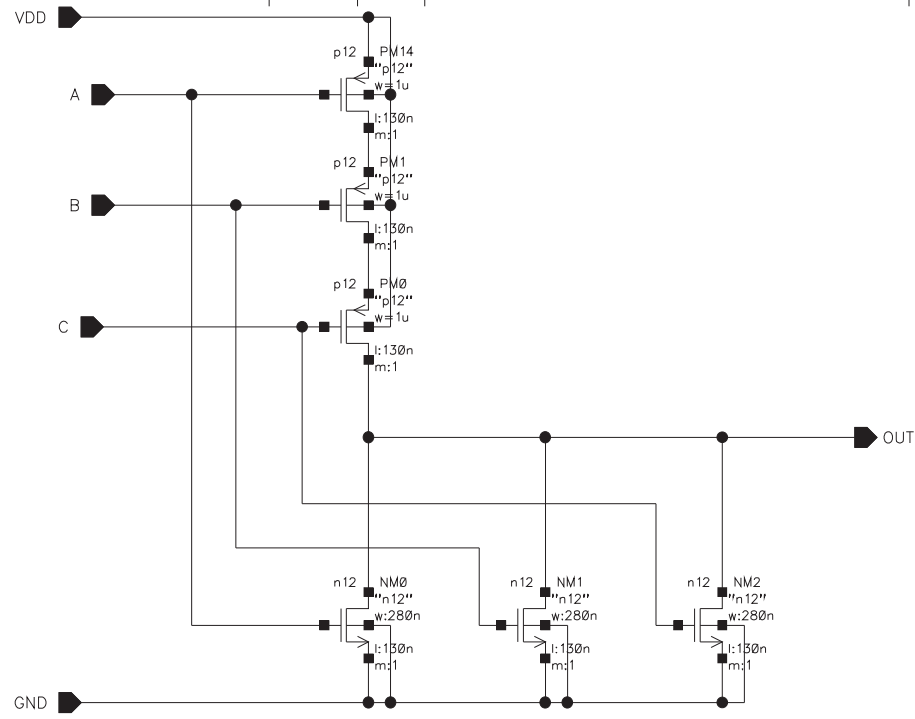

UPDATED				
Oct 25 01:50:07 2006				
DRAWN	nor3_12v_1x			
CHECKED				
CHECKED	SIZE	CAGE NO.	DWG NO.	REV
ISSUED	A			
	SCALE		SHEET	OF

REVISIONS				
ZONE	REV	DESCRIPTION	DATE	APPROVED

Design Notes:
8nS tt overlap; 0.4nS rise/fall time.

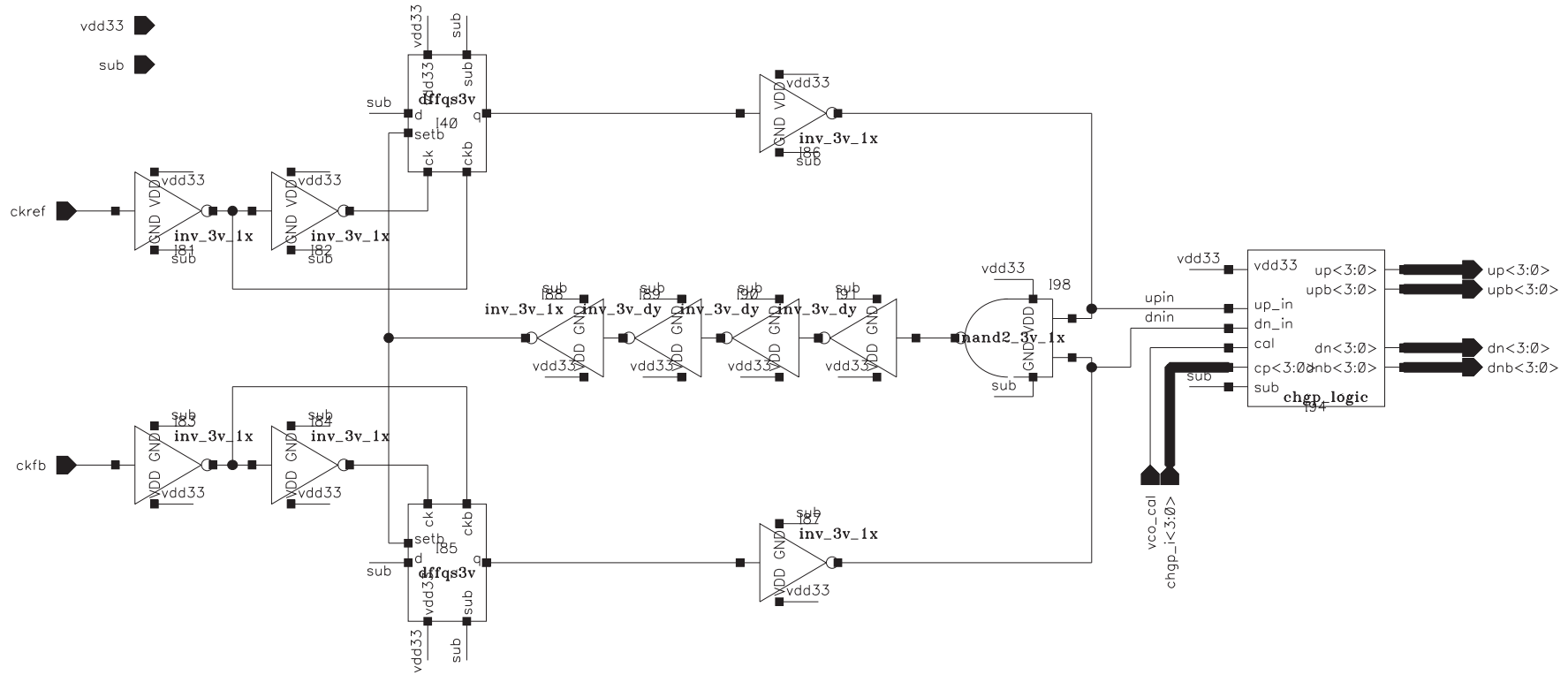

- Layout Notes:
1. This VDD should directly go to a dedicate pad, separate from VCO vdd33.
 2. Match output up, upb, dn, dnb routings to Chgp block.

UPDATED				
Oct 25 01:50:08 2006				
DRAWN				
CHECKED				
CHECKED	SIZE	CAGE NO.	DWG NO.	REV
ISSUED	A			
	SCALE		SHEET	1 OF 1

REVISIONS				
ZONE	REV	DESCRIPTION	DATE	APPROVED

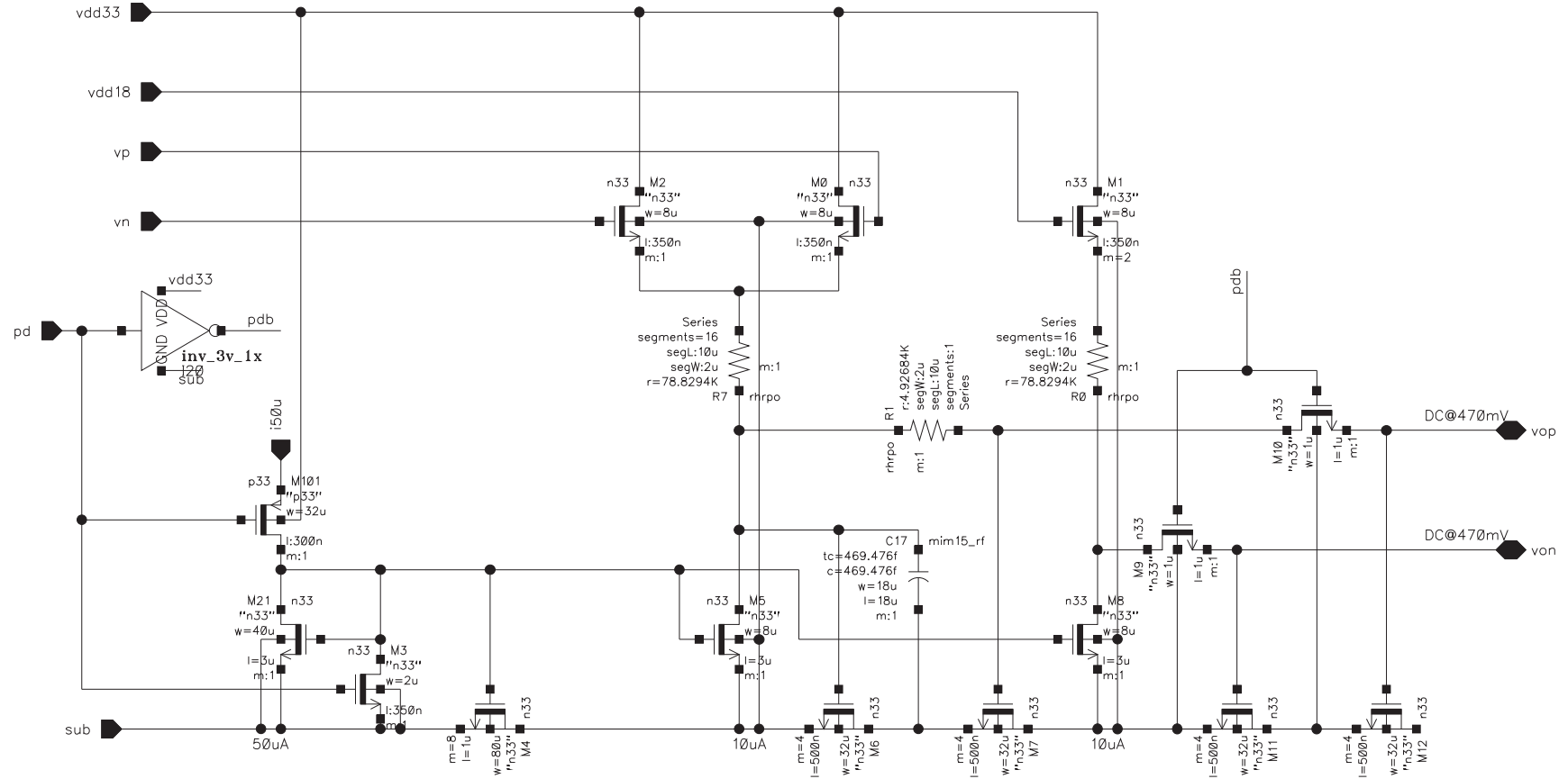

Layout Notes:
 1. Inter-digi transistors M0, M1 and M2.
 2. Keep device size (W,L,m and fingers) exactly as shown in the schematic except M4, including M6,M7,M11,M12.

UPDATED

Nov 8 08:28:39 2006

DRAWN

CHECKED

CHECKED

ISSUED

pkdet_vco

SIZE	CAGE NO.	DWG NO.	REV
A			
SCALE	SHEET		1 OF 1

REVISIONS				
ZONE	REV	DESCRIPTION	DATE	APPROVED

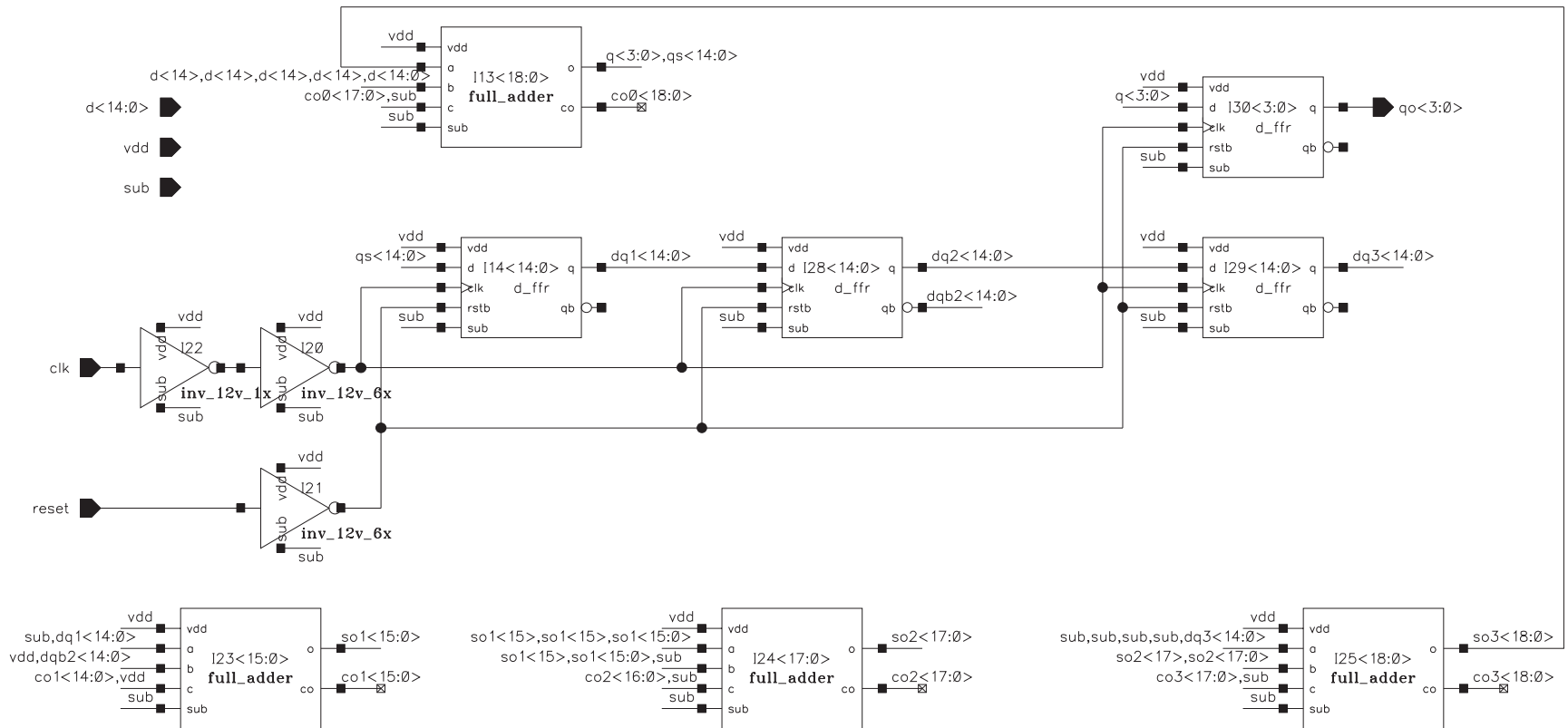

UPDATED	Dec 14 03:22:21 2006			
DRAWN	sigma_delta_3rd			
CHECKED				
CHECKED	SIZE	CAGE NO.	DWG NO.	REV
ISSUED	A			
	SCALE		SHEET	1 OF 1

REVISIONS				
ZONE	REV	DESCRIPTION	DATE	APPROVED

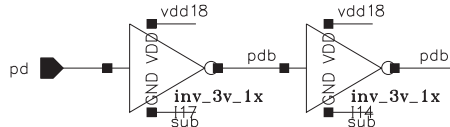
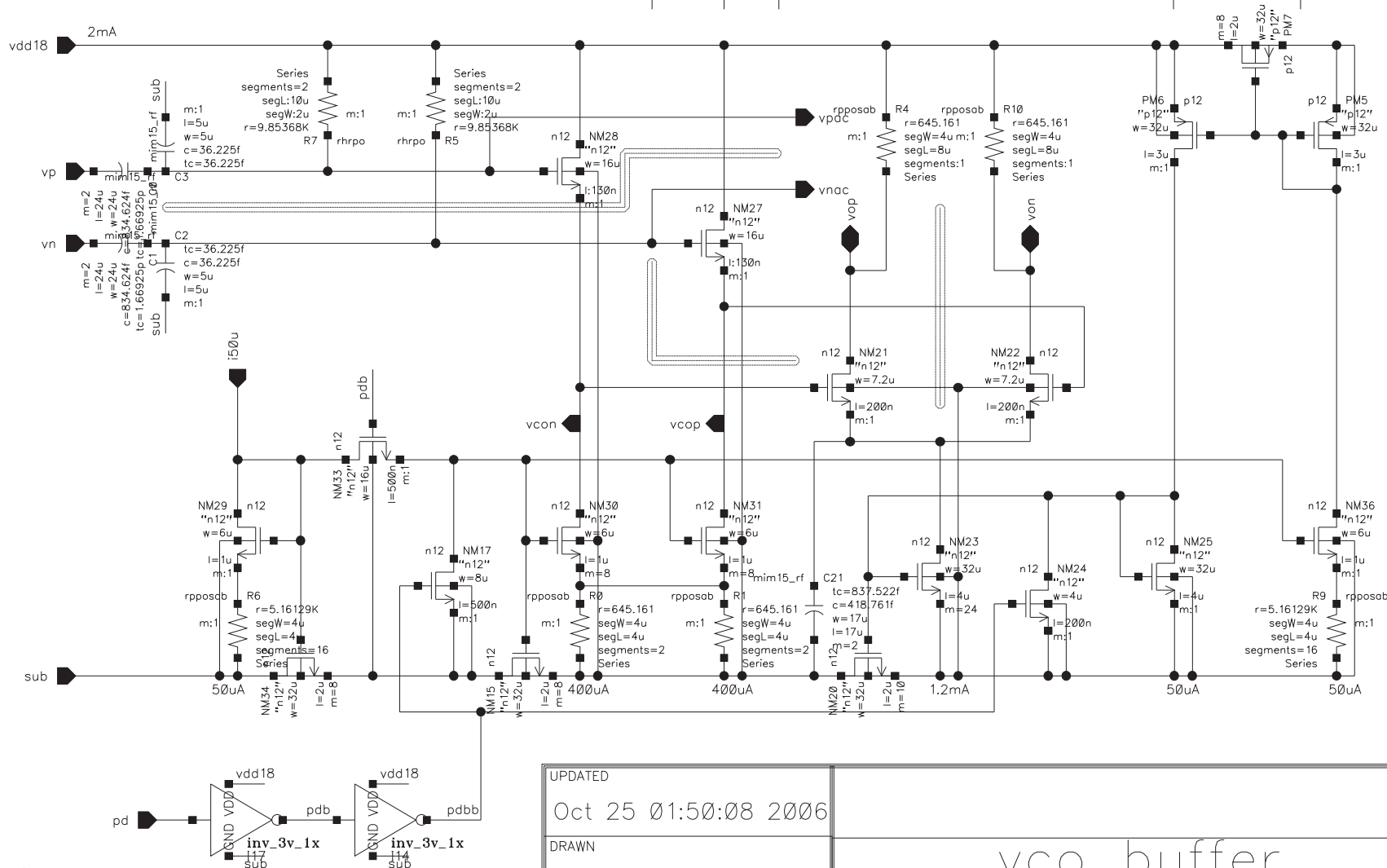

Layout Notes:

1. Keep device size (W,L,multiples, fingers) exactly as shown in the schematic except MN15, MN20, MN34 and PM7. These devices size can be changed but keep their WxL size at least the same as the schematic.
2. Inter-digi for NM21 with NM22, NM27 with NM28.
3. RF path are annotated with wide dashed lines. Keep this routing short with 3u width, 5u spacing top metal as primary routing.

UPDATED		Oct 25 01:50:08 2006		
DRAWN		vco_buffer		
CHECKED				
CHECKED	SIZE	CAGE NO.	DWG NO.	REV
ISSUED	A			
SCALE			SHEET 1 OF 1	

REVISIONS				
ZONE	REV	DESCRIPTION	DATE	APPROVED

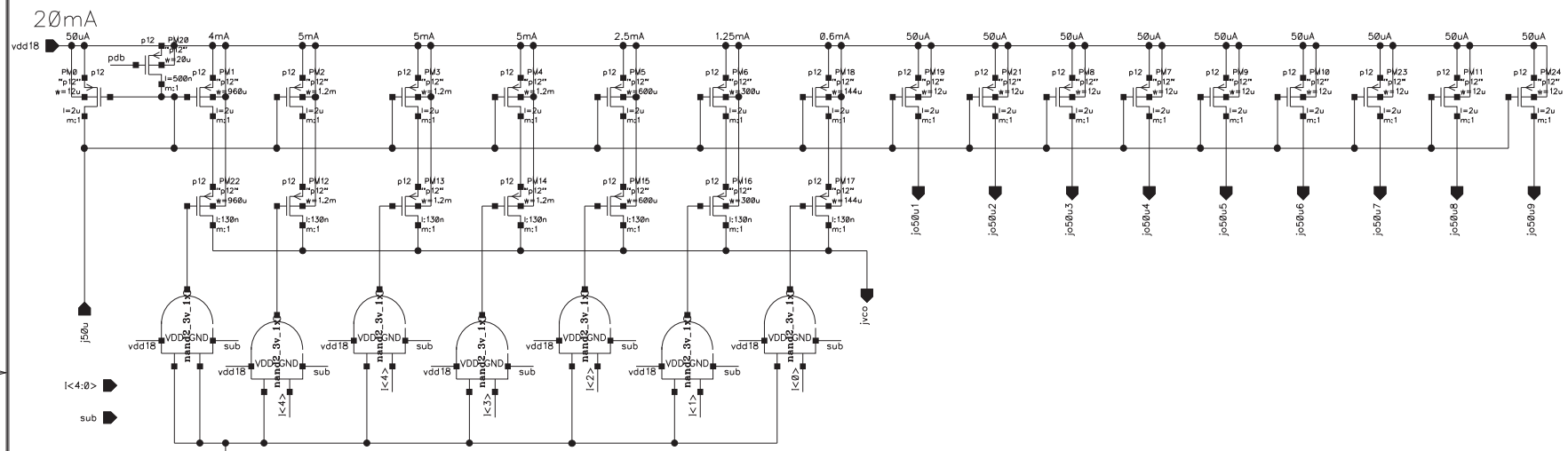

Layout Notes:
 1. Keep the layout device sizes (W,L,etc.) exactly the same as the schematic.
 2. Dual gate style layout can be used to save die size.

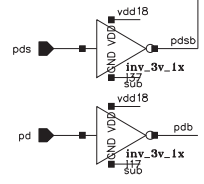

UPDATED	Oct 25 01:50:08 2006			
DRAWN	VCO_ib			
CHECKED				
CHECKED	SIZE	CAGE NO.	DWG NO.	REV
ISSUED	B			
	SCALE		SHEET	1 OF 1

REVISIONS				
ZONE	REV	DESCRIPTION	DATE	APPROVED

Layout Notes:
 1. Signals CON, CONREF, J50U go to bonding pads. Keep them close as a group with 3u width each and shield them with SUB.
 2. RF path are annotated with wide dashed line. Keep these lines short using 2u width, 4u spacing top metal as primary routing.
 3. Use top metal for large current power routings. Double or triple the metal layers if necessary to reduce the required power metal width.

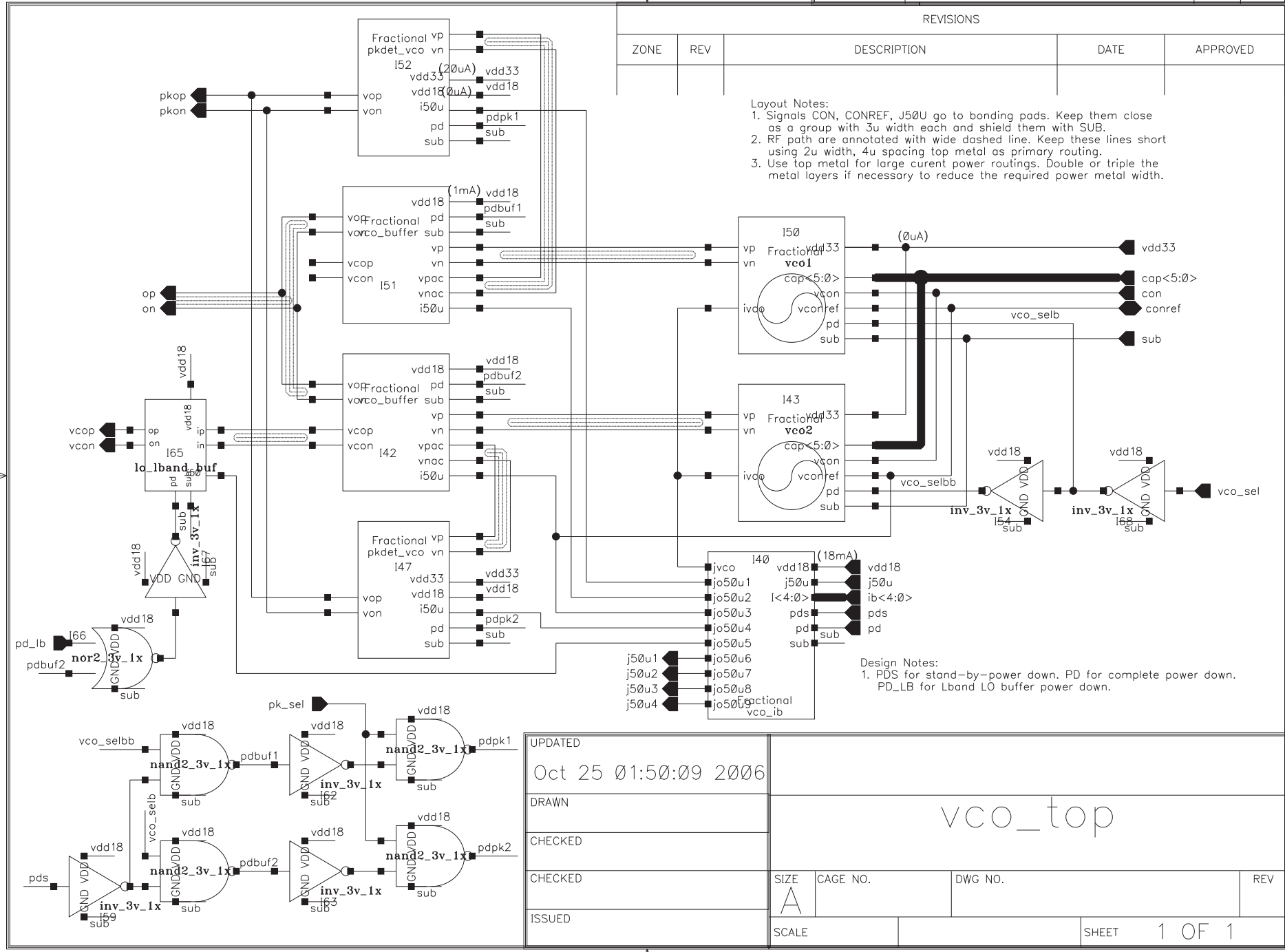

Design Notes:
 1. PDS for stand-by-power down. PD for complete power down. PD_LB for Lband LO buffer power down.

UPDATED	Oct 25 01:50:09 2006		
DRAWN	vco_top		
CHECKED			
CHECKED	SIZE	CAGE NO.	DWG NO.
ISSUED	A		
	SCALE		SHEET 1 OF 1

REVISIONS				
ZONE	REV	DESCRIPTION	DATE	APPROVED

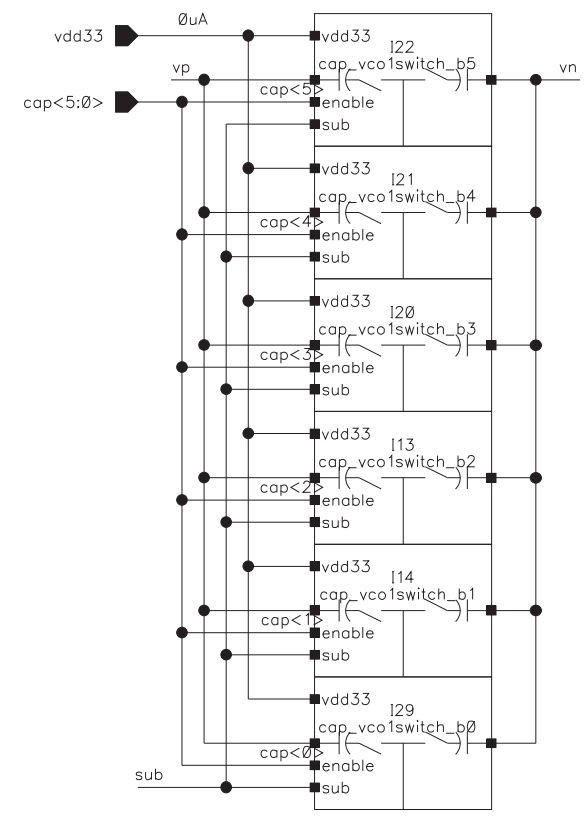
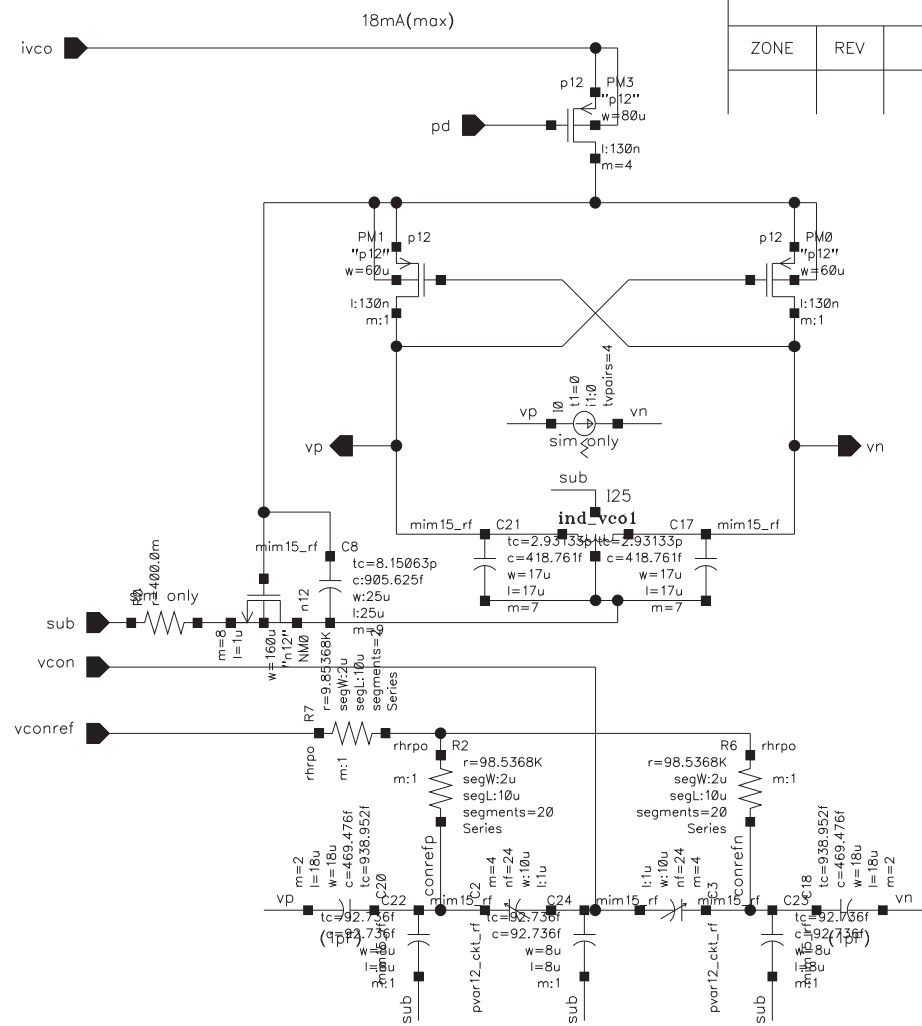

- Layout Notes:
1. This is a differential circuit. Mirror style matching required.
 2. Inter-digi PM0 with PM1.
 3. VCON and VCONREF both go to pins. Shield their routing by sub.
 4. Minimize routing length (minimize routing resistance) from inductor to C18/C20, C2/C3 varactors and the 6-bit switched capacitors.
 5. Size of NM0 is approximate, it's W and L can be changed depending on available space but keep WxL the same or larger.

UPDATED	Oct 25 01:50:08 2006
DRAWN	vco1
CHECKED	
CHECKED	
ISSUED	

SIZE	CAGE NO.	DWG NO.	REV
A			
SCALE	SHEET 1 OF 1		

REVISIONS				
ZONE	REV	DESCRIPTION	DATE	APPROVED

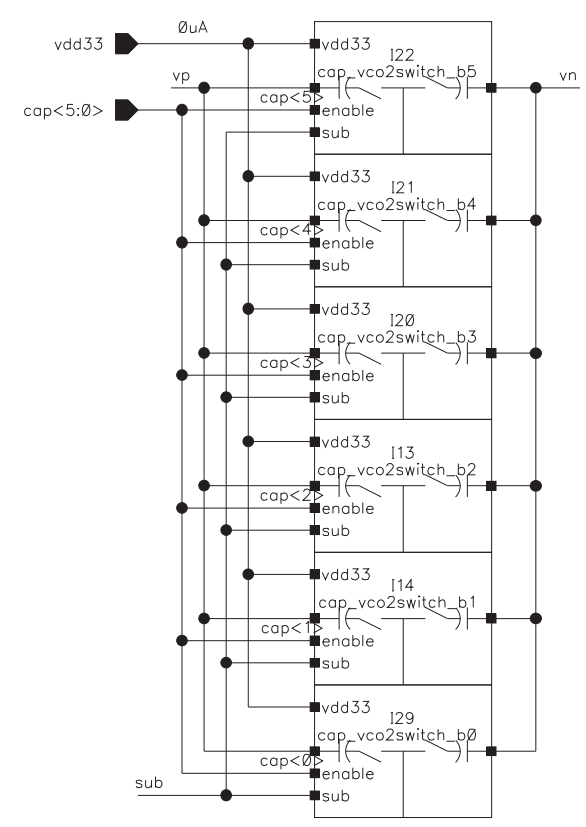
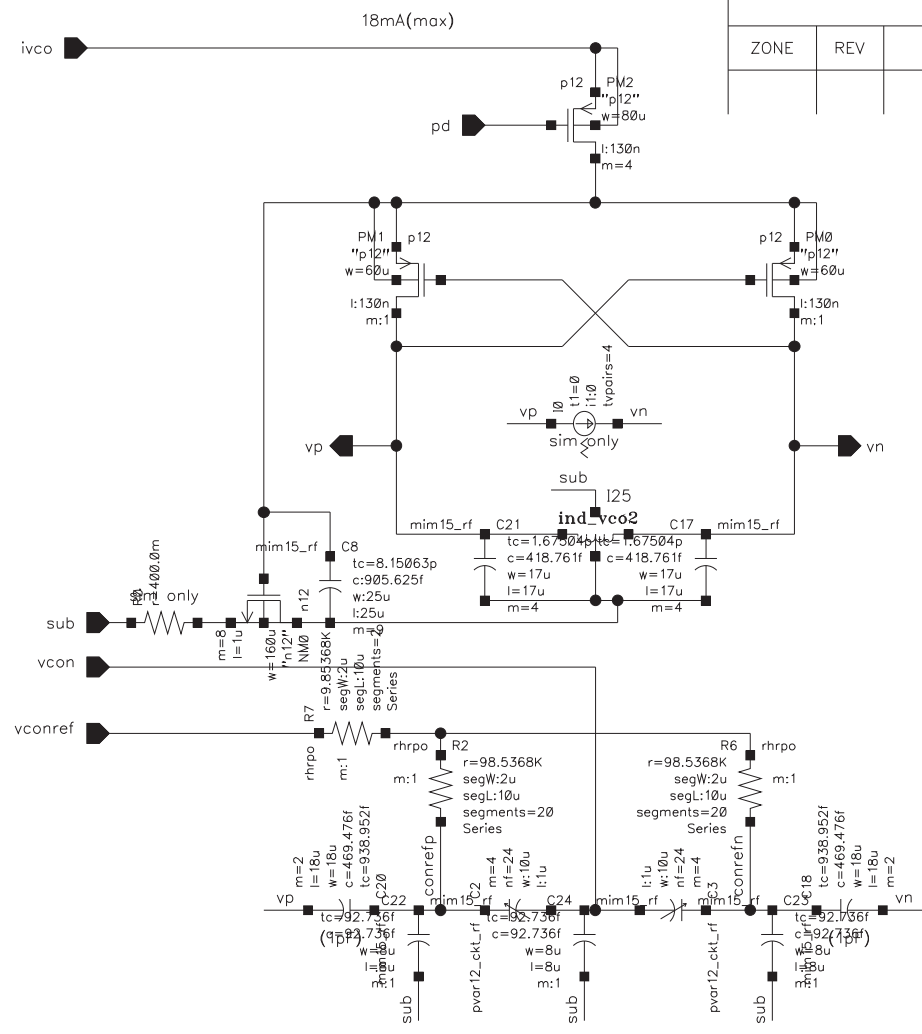

- Layout Notes:
1. This is a differential circuit. Mirror style matching required.
 2. Inter-digi PM0 with PM1.
 3. VCON and VCONREF both go to pins. Shield their routing by sub.
 4. Minimize routing length (minimize routing resistance) from inductor to C18/C20, C2/C3 varactors and the 6-bit switched capacitors.
 5. Size of NM0 is approximate, it's W and L can be changed depending on available space but keep WxL the same or larger.

UPDATED		Oct 25 01:50:08 2006				
DRAWN		vco2				
CHECKED						
CHECKED	SIZE			CAGE NO.	DWG NO.	REV
ISSUED	SCALE			SHEET 1 OF 1		

REVISIONS				
ZONE	REV	DESCRIPTION	DATE	APPROVED

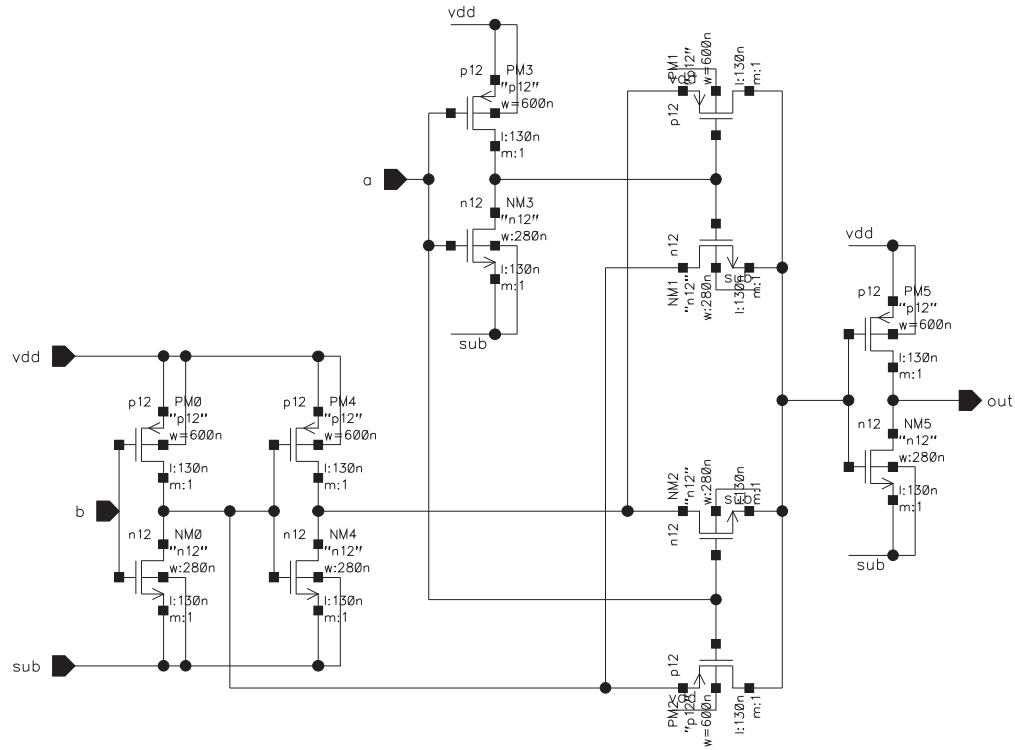

UPDATED	Oct 25 01:50:07 2006
DRAWN	
CHECKED	
CHECKED	
ISSUED	

xor_12v			
SIZE	A	CAGE NO.	DWG NO.
SCALE		SHEET	1 OF 1

primRes2



R0

"rhrpo"
r:pPar("segR")
w:pPar("segW")
l:pPar("segL")

primRes2



R1

"rhrpo"
r:pPar("segR")
w:pPar("segW")
l:pPar("segL")

PLUS



MINUS



